

INSTRUCTION BOOK

MODEL 200A

MAGNETIC TAPE RECORDER



AMPEX ELECTRIC CORPORATION

SAN CARLOS, CALIFORNIA

Contents . . .

	PAGE
Introduction	3
Performance Characteristics	3
Tape	5
Drive System	5
Head Housing	8
Electronic System	8
Controls	11
Installation and Operation	12
Adjustments	14
Maintenance	19
Demagnetizing Heads	20

INSTRUCTION BOOK NO. 11.....

ISSUED FOR

AMPEX MAGNETIC TAPE RECORDER NO. 19.....

INTRODUCTION

The AMPEX Magnetic Tape Recorder has been so designed as to make the highest quality of recordings possible to achieve. Using the best possible input and monitoring equipment, recordings cannot be distinguished from original program material when directly compared. All components have been conservatively designed, using the best possible materials, in order to insure maximum reliability of service.

PERFORMANCE CHARACTERISTICS

The specifications of the AMPEX Magnetic Tape Recorder are as follows:

FREQUENCY RESPONSE: 30 to 15,000 cycles \pm 1 db.

DISTORTION: Distortion in the overall system (from input terminals to output terminals) at peak meter reading does not exceed 4% *intermodulation distortion*, using measuring frequencies of 100 and 2,000 cycles with the high frequency attenuated 12 db. Total r.m.s. harmonic distortion does not exceed 1% overall for any single frequency from 100 to 6,000 cycles and 2% for any frequency from 30 to 100 cycles.

SIGNAL TO NOISE RATIO: The noise level of the system is over 60 db. below 100% modulation. One hundred per cent modulation is defined as 10 db. above peak meter reading, at which point total harmonic distortion does not exceed 5%. The noise level is that signal which exists at the output terminals of the playback amplifier when recording in the normal manner with the record input terminals terminated in a resistance equal to the rated source impedance. It therefore includes record and playback amplifier noise, any noise caused by bias or erasing and any stray pickup in the heads. This measurement is made unweighted over a frequency range of 30 to 15,000 cycles and with a tape that has been previously modulated 100% with a 400-cycle tone.

MONITORING: Instantaneous monitoring made possible by separate record and playback heads and amplifiers.

RECORD AMPLIFIER: Will provide 100% modulation with an input signal between - 15 d.b.m. and + 20 d.b.m. 150 or 600 ohms input impedance. (Bridging input optional.)

PLAYBACK AMPLIFIER: 100% modulation will give an output up to 30 d.b.m. Normally adjusted for peak output of +4 VU (100% modulation gives +14 d.b.m.). Output impedance 150 or 600 ohms. Adjustment of both high and low frequency equalization is provided on both record and playback amplifiers by means of screwdriver adjustments. All gain controls, including erase and bias currents, are also screwdriver adjustments.

CHASSIS: All chassis of plug-in construction.

HEADS: Plug-in head assembly for rapid changing of heads and to expedite head exchange service. Carefully shielded and designed for convenient and rapid threading of tape. Recording and playback gaps critically aligned allowing interchangeability of recordings without high frequency loss.

TAPE SPEED: 30 inches per second for normal playing, over 300 inches per second average during rewind or fast forward.

TIMING: Accuracy of playback timing \pm 0.03%.

MARKING: A marking device incorporated over the playback head for spotting tape in editing operations.

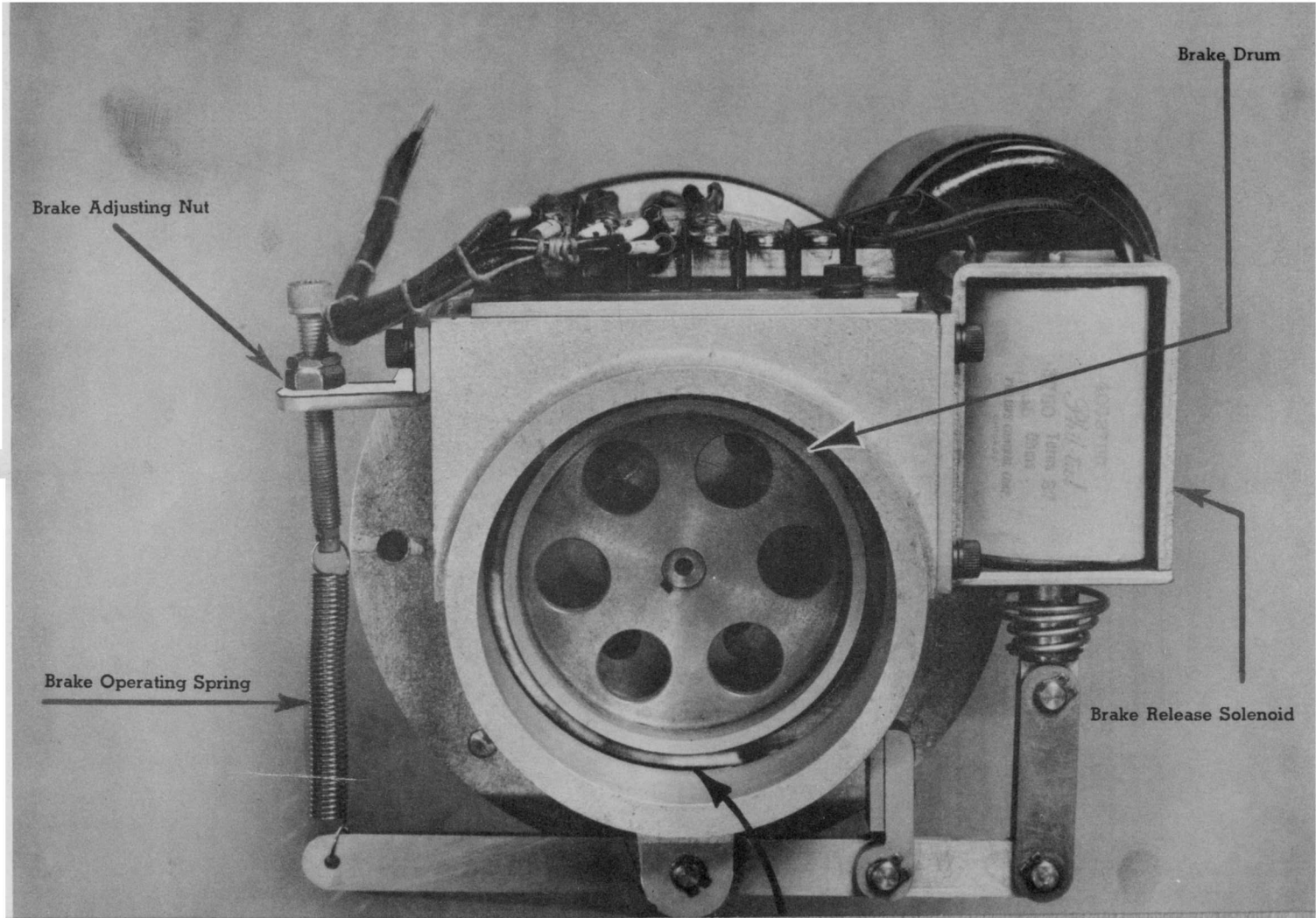

Brake Adjusting Nut

Brake Operating Spring

Brake Drum

Brake Release Solenoid

RECORDING TIME: 35 minutes per reel.

TAPE MOUNTING: On 4-inch diameter hub with single 14-inch diameter flange attached for safe and convenient handling of valuable program material. Design of driving spindles allows reels to be placed on or removed from recorder quickly and conveniently. Hub design permits rapid tape threading.

T A P E

Sufficient reserve capacity and flexibility have been designed into the amplifiers so that any of the leading makes of tape may be accommodated. However, as shipped the machine has been specifically set up for the use of Minnesota Mining & Mfg. Co. type RR tape, as this tape has been found to give the best signal-to-noise ratio with the minimum modulation noise and other undesirable effects. In general, plastic-backed tapes are superior to paper tapes, as they are quieter and more uniform in their characteristics, and have less tendency to sludge and foul the heads.

D R I V E S Y S T E M

The drive system consists of three motors: the capstan motor, which is a hysteresis synchronous motor for driving the tape at a constant speed of 30 inches per second; a takeup motor for winding up the tape paid out by the capstan; and a rewind motor, which provides back tension on the tape during normal playing and rewinds the tape after it has been played.

The takeup and rewind reels rest on turntables attached directly to the motor shafts. The motors are double ended, and a cast iron brake drum is mounted on the lower shaft extension. A band-type brake is employed, the brakes being applied by springs and released by solenoids. This construction is illustrated in Fig. 1. The brakes are designed to apply greater braking force in the direction of rotation in which the reel pays out tape, so that the unwinding reel will always tend to stop the fastest, thereby keeping tension in the tape at all times during stopping. The rewind and takeup motors are specially designed for the proper torque characteristics during all operating conditions. Torques are adjusted so that at no time does the tape tension exceed 12 ounces.

The capstan is a hardened steel shaft mounted in its own bearing housing, and is coupled to the drive motor through a flexible coupling. A solenoid operated rubber idler clamps the tape against the capstan shaft for normal playing speed. The whole capstan drive assembly is mounted on a plate which can be tilted to insure optimum tracking of the tape through the capstan. This assembly is shown in Fig. 2.

The tape passes over a tension arm on each side of the head housing. These take up the slack in the tape, smooth out variations in tension, and absorb the shock of starting and stopping. The tension arm on the takeup side is equipped with a micro-switch or safety switch (S7) which shuts the machine off if the arm is allowed to move to the end of its clockwise travel. Thus, if the tape should break or run out, the machine will automatically shut off. **THE SLACK MUST BE TAKEN OUT OF THE TAPE AND THE TAKEUP TENSION ARM PLACED IN THE PROPER OPERATING RANGE BEFORE THE MACHINE WILL START.**

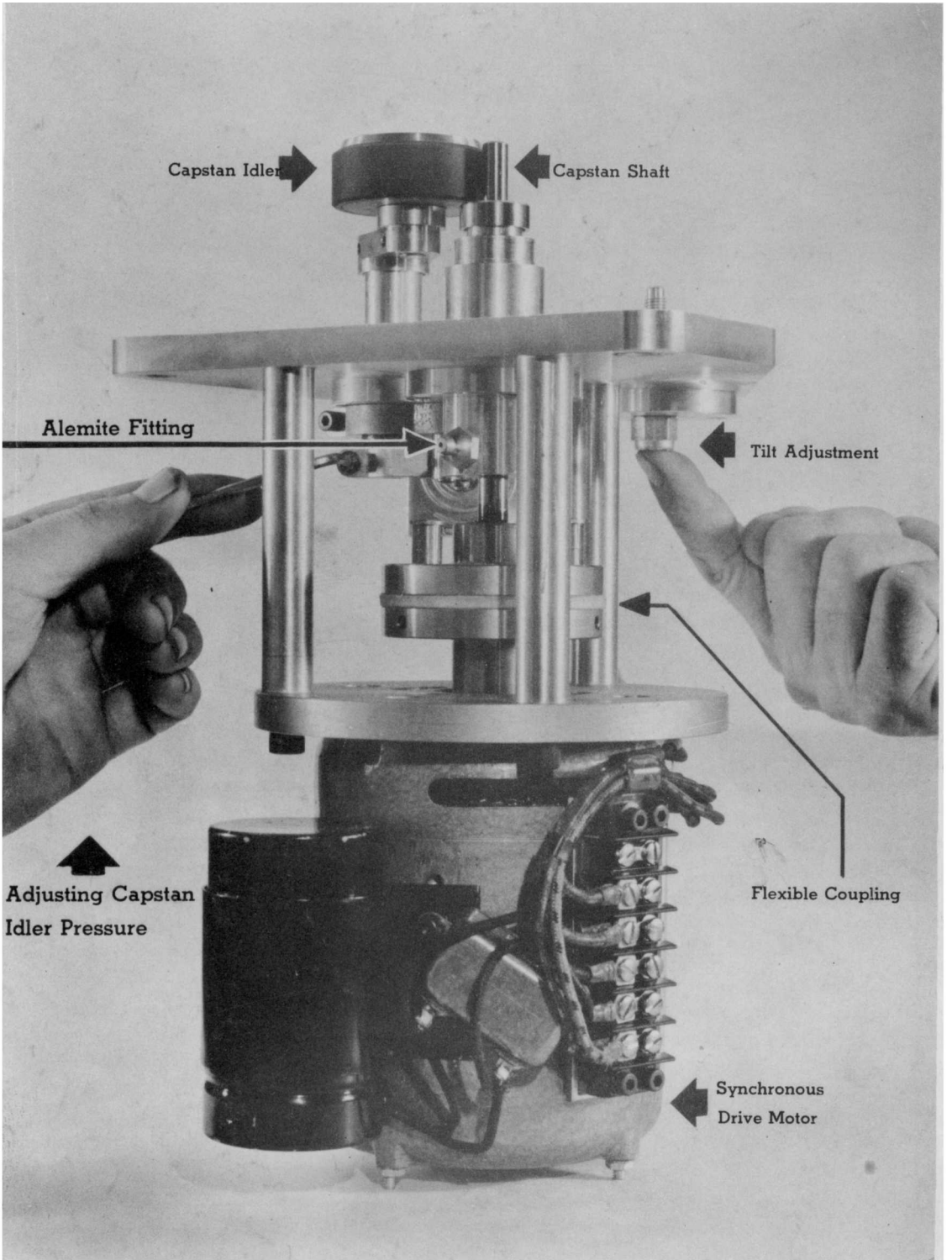

FIGURE 2.

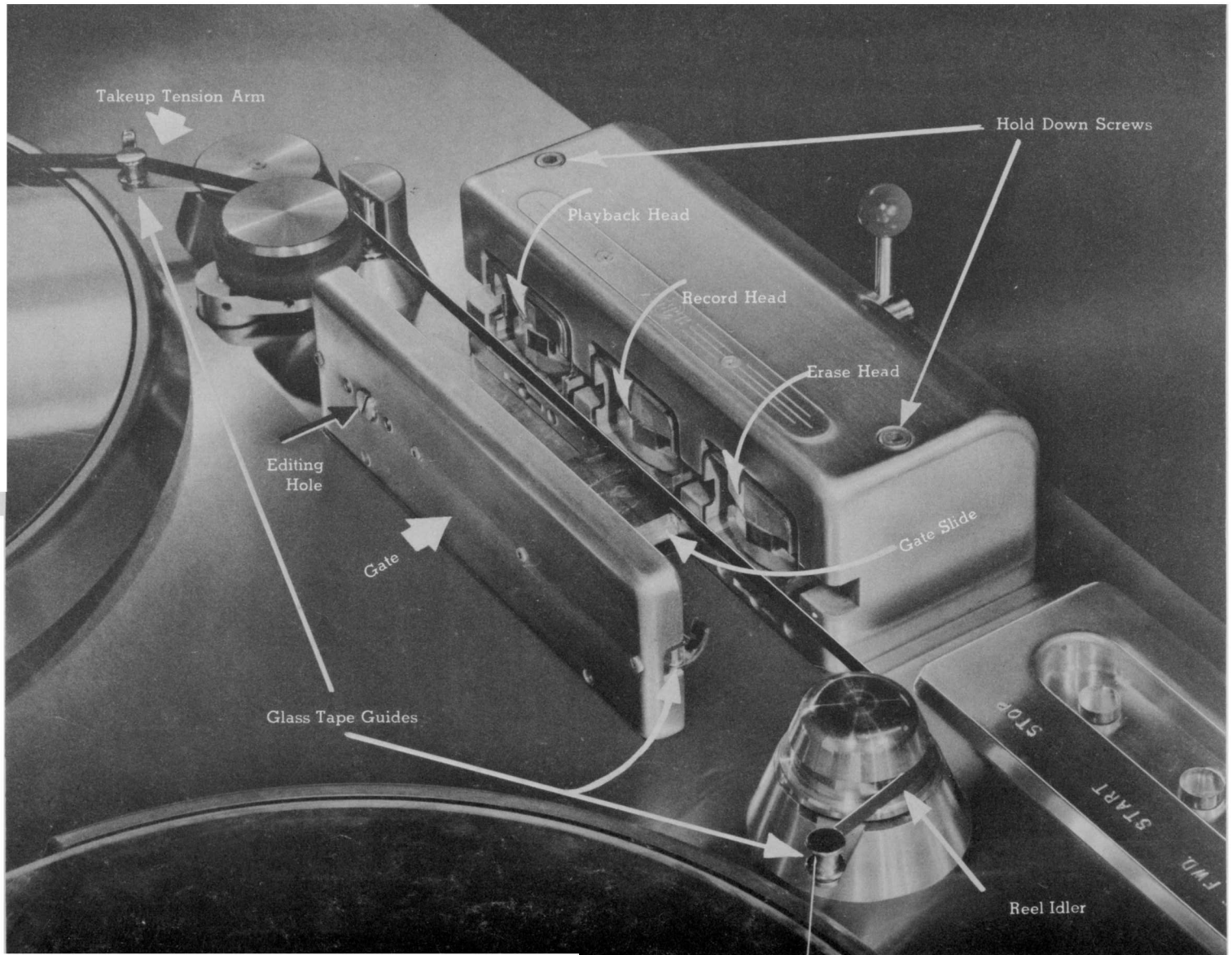

FIGURE 3.

HEAD HOUSING

Figure 3 illustrates the head housing with the gate retaining springs removed so that the gate is opened to expose the heads. The playback head, which appears on the extreme left, is contained in two mu-metal shield cans with a copper shield can in between. Matching coverplates on the gate, consisting of three mu-metal plates insulated with non-magnetic spacers, cover the front of the playback shield cans when the gate is closed to provide completely enclosed shielding. The record and playback heads are each contained in a copper shield can. The head housing and gate are malleable cast iron, which provides further shielding. The head housing is a plug-in unit, and is removed by loosening the two captive screws with the crank provided in the machine.

The individual heads are mounted by two studs which extend through the top of the head housing into a recess which is covered by the nameplate. Removing the nameplate on top of the head housing exposes the retaining lock-nuts on the mounting studs. In the case of the record and playback heads, the mounting is designed to allow vertical alignment of the head gaps. One side of the head baseplate rests on two small ball pivot points, and the other side against a spring. Rotating the locknut on the right hand stud (when facing the machine) varies the compression of the spring and therefore the alignment.

The opening and closing of the gate is cam operated from the handle on the rear of the head housing. Tape guides on the inside of the gate hold the tape at the proper vertical position. When the gate is open, the tape is removed from contact with the heads. The position of the guides is such that when the gate is closed, the tape makes a slight wrap around each head.

ELECTRONIC SYSTEM

The electronic system consists of the record amplifier, playback amplifier, power supply, and relay chassis for controlling all operations. All four chassis are of the plug-in type, mating with plugs in a wiring gutter in the back. All external connections are made to receptacles provided in this gutter, which are made available by removing the panel in the back of the cabinet. The entire chassis assembly is resiliently mounted to protect from shock during shipping and to isolate the amplifiers from vibration.

To remove a chassis, use the crank provided in the clip on the left hand (when facing cabinet) inner wall of the cabinet.

1. Loosen hold-down screws at the front of the chassis bottom plate (and remove head connector cables in the case of record or playback chassis).
2. Insert crank in the Allen head screw in front under chassis, and rotate *clockwise* as far as it will go. (See Fig. 4.)
3. Lift handle to disengage bottom plate from drive pin and pull chassis out.

To replace chassis, slide chassis in proper ways until drive pin engages in the hole provided in the front extension of the bottom plate. Turn crank *counter-clockwise* as far as it will go, and tighten hold-down screws.

Connections for remote control are provided on the wiring gutter. It is necessary for pins 9 and 10 on the remote control connector to be jumpered before the machine can be started. This jumper is provided in the mating plug furnished with the machine. Fig. 14 is the wiring diagram for the remote control panel.

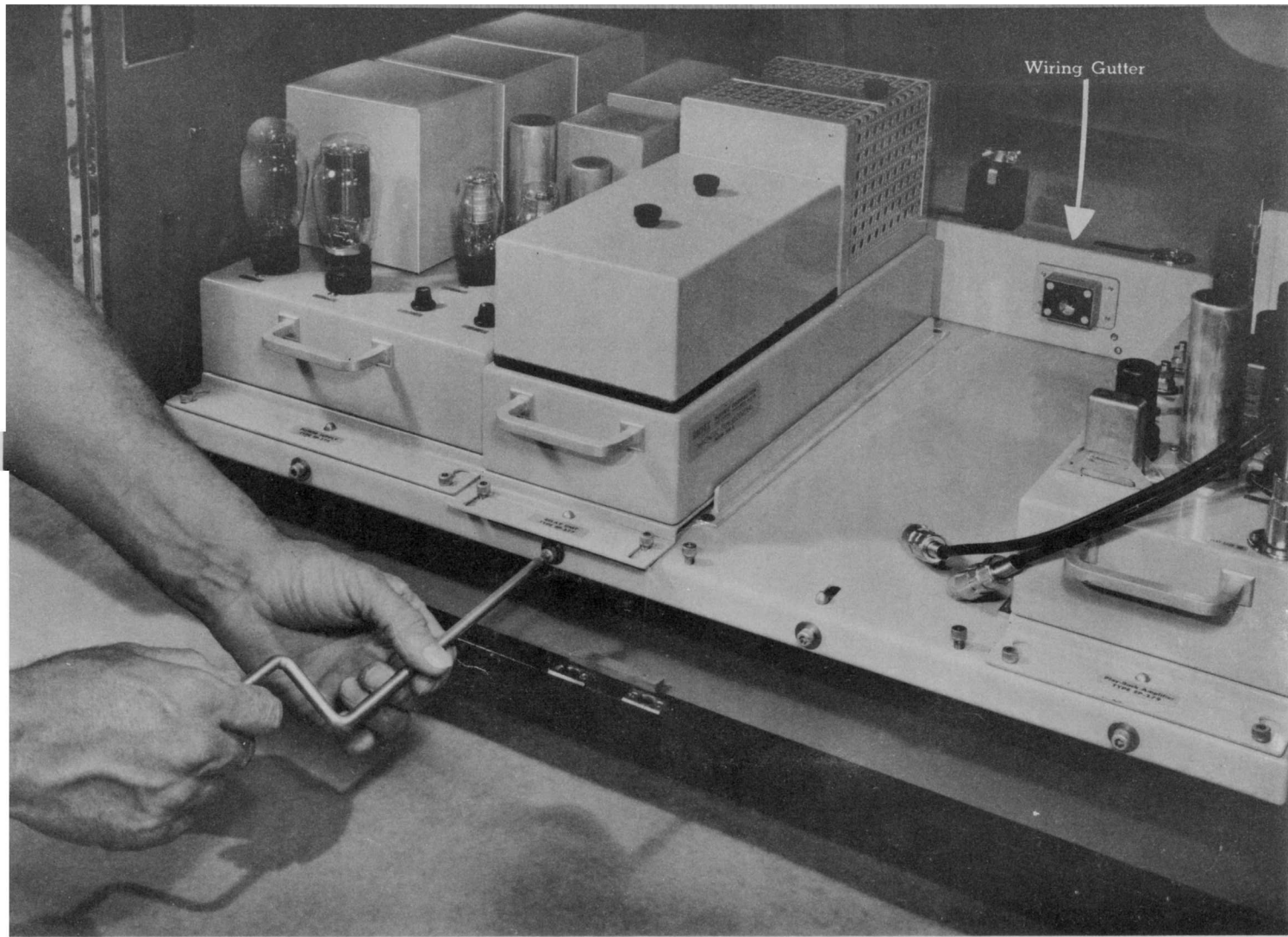

POWER SUPPLY: The power supply diagram is shown in Fig. 8. It consists of a 360 volt supply for the erase, bias, and playback output tubes plate voltage, and a regulated 300 volt supply for the record and playback amplifiers, the oscillator, and erase and bias screens. In addition, there is a D. C. filament supply for the playback amplifier, a 36 volt A. C. output to provide 24 volts D. C. for all relays and solenoids, and filament supply for all tubes.

RELAY CHASSIS: The relay chassis wiring diagram is shown in Fig. 9. This chassis contains a selenium rectifier for the 24 volt D. C. supply, and all relays. The operation of the relays is shown schematically in Fig. 12, and explained below under **CONTROLS**.

RECORD AMPLIFIER: The record chassis, Fig. 10, contains the record amplifier for matching a 150 or 600 ohm line and converting the incoming signal to constant current in the record head, a 60 kc. oscillator, and separate power amplifiers for providing 60 kc. bias and erase currents.

The record amplifier is provided with screwdriver adjustments for gain and equalization so that different machines can be adjusted to have identical characteristics. The general method of overall equalization is to boost both high and low frequencies during recording, and attenuate as necessary on playback. The low and high frequency controls are set to give flat overall frequency response, and each machine is checked to match a standard tape to insure that recordings will be interchangeable among machines. One stage of amplification is provided in the triode, V301. A 6AC7, V302, is used on the output as a current converter. The transformer T302 operates as a current transformer to further increase the record current, and the record current is fed back through the cathode of the output tube V302 to decrease distortion and flatten the frequency response. The record amplifier is capable of producing five times as much undistorted signal as is necessary to fully modulate the tape.

The oscillator tube V303 uses a high Q tank circuit to provide excellent wave form, and drives V304 to provide bias current and V305 for erase current. The bias output is tuned to the record head by means of trimmers C317 and C318 for minimum noise. The erase output is matched to the erase head with trimmer C319, which is also tuned for minimum noise. The oscillator plate voltage and bias and erase tube screens are supplied from the regulated 300 V. supply.

PLAYBACK AMPLIFIER (Fig. 11): The playback amplifier is designed to operate directly from the playback head, and contains the necessary amplification and equalization to provide flat frequency response and a maximum output level of 30 DBM into a 150 or 600 ohm line from a fully modulated tape.

The playback head output is fed directly into a pentode stage, V401. This is followed by an equalization network to compensate for the voltage characteristic of the playback head. R406 in series with capacitor C404 provides 6 db. per octave attenuation up to around 4,000 cycles, where the response is leveled out by R407. With high and low frequency controls R430 and R431 respectively all the way up, the overall response is boosted at both ends. These controls are therefore set to give flat overall response, and are screwdriver adjustments. The low frequency control is normally set at the minimum position (all the way counter-clockwise) for best overall signal-to-noise ratio.

Machines starting with serial number 20 are equipped with a different kind of playback cable which extends the range of the response. With this cable, an additional

arm consisting of C419 and R432 is necessary to flatten the response. When different head assemblies are used, it may be necessary to slightly alter the value of C409 and/or C419 to keep the response within ± 1 db.

C414 and C415, in conjunction with L401 and L402, provide a 60 kc. wavetrap to remove the bias and erase frequency from the playback output. C414 and C415 are air trimmers with screwdriver adjustment.

All tubes except the output stage are D. C. heated. The first two stages of the amplifier are resiliently mounted. The first stage tube, V401, is selected for low noise level and low microphonics. Of the five 12SJ7's in the amplifier, at least two or three are satisfactory for the first stage.

An isolation pad is provided on the output of the playback amplifier. This pad plugs into the octal socket provided on the rear wiring gutter. Since the maximum operating level of the playback amplifier is 30 dbm. without distortion, the gain setting should be such that the peak output level plus the loss in the pad provided does not exceed 20 VU. This setting will allow 10 db. for transient peaks without distortion. The machine is normally adjusted for a peak output level of + 4 VU.

CONTROLS

The following controls are provided:

1. Start, which provides normal playback at 30 inches per second.
2. Record.
3. Fast forward, for shuttling the tape in the forward direction at high speed (more than 10 times playing speed).
4. Rewind, for rewinding the tape at high speed (more than 10 times playing speed).
5. Stop.

None of the controls can be operated unless the Start button is first operated. When it is desired to start the machine in any of the other conditions, the Start button must be operated simultaneously with the desired button. Once the Rewind or Fast Forward button has been operated, it is necessary to depress the Stop button to select another mode of operation.

The operation of the controls can be followed in the schematic control diagram, Fig. 12. When the power is turned on, the power supply and all filaments are energized. Plate voltage is connected to both record and playback amplifiers. The record head, however, is disconnected from the record amplifier by the normally open contacts K204-2, and the record output is grounded through the normally closed contacts K204-2, which also charges condenser C315 and thereby prevents a current pulse through the record head when the record head is connected to the output. The stop light is energized through normally closed contacts K201-2.

Depressing the Start button provides normal playback operation. The brake solenoids pick up, extending the brake springs and releasing the brakes, the capstan solenoid picks up, clamping the tape against the capstan, relay K201 picks up through the normally closed Stop switch contacts, providing the tape has been pulled up to swing the takeup tension arm into normal playing position, which leaves the safety switch S7 contacts closed. When relay K201 picks up, it locks in the start switch and energizes the capstan, takeup, and rewind motors. The takeup motor is energized at 65 volts through resistor R202, while the rewind motor provides holdback by being energized

at 60 volts through R203. The time relay K205 is picked up, the start light is energized, and the stop light disconnected.

Pressing the record button picks up the record relay K204, which locks itself in, energizes the record light, connects the record head to the record amplifier output, and supplies plate voltage to the oscillator, bias and erase tubes. All motor connections remain the same.

Operating the Rewind button picks up relay K202, which locks itself in, energizes the Rewind light, applies 90 volts to the rewind motor through resistor R205, energizes the takeup motor at 30 volts through R201, and disengages the capstan solenoid from the capstan, allowing the tape to move at high speed. The record relay K204 is also dropped out, and the Fast Forward relay is locked out.

Depressing the Fast Forward button causes relay K203 to pick up and lock itself in, energizes the Fast Forward light, applies 90 volts to the takeup motor, energizes the rewind motor at 30 volts through R201, and disengages the capstan solenoid. The record relay is dropped out (or locked out), and the Rewind relay is locked out.

When the Stop button is depressed, relay K201 drops out, which drops out all relays, solenoids, and motors. De-energizing the brake solenoids allows the springs to apply the brakes to the rewind and takeup reels. Relay K205 does not drop out for over one second because of the condenser C204 across it which holds up the voltage. Thus for a brief moment D. C. is applied to the capstan motor, which stops the capstan. While there would be no harm in leaving the D. C. on the capstan motor all the time the machine is not running, the time delay relay is provided to disconnect the D. C. after the motor stops, to eliminate the audible hum of the motor due to the unfiltered D. C. source. Stopping the capstan shaft is necessary to allow immediate restarting without throwing a loop of tape.

(*Note:* Because of procurement difficulties, it has not always been possible to use the same make of motors. Motors of different manufacture may require different resistors and voltage settings. The above description applies to Electric Indicator motors. Motors manufactured by Bodine Electric Co. require a resistor in series (R205) during Fast Forward and Rewind operations to drop the voltage on the motor taking up the tape to 85 volts. Proper settings during normal playing are 60 volts on the takeup motor and 55 volts on the rewind motor.)

INSTALLATION AND OPERATION

To install the machine, remove the back panel and connect power, input, output, and remote control (if required) cables to the plugs provided.

To operate the machine, the roll of tape is placed on the rewind turntable, which is the one on the left when facing the machine. The recommended threading procedure is the "straight through" method in which the tape is passed behind the rewind idler tension arm guide, around the rewind idler, through the head housing, between the capstan and capstan idler, over the takeup tension arm and thence to the takeup reel. To thread the tape on the takeup reel, form a small loop at the end of the tape as shown in Figure 5, slide the loop over one of the drive pins and pull both sides of the loop through the slot opening. If the end of the tape is on the side toward the front of the machine, rotating the reel counter-clockwise and putting tension on the tape will automatically cinch the tape. When the slack is taken out of the tape and the

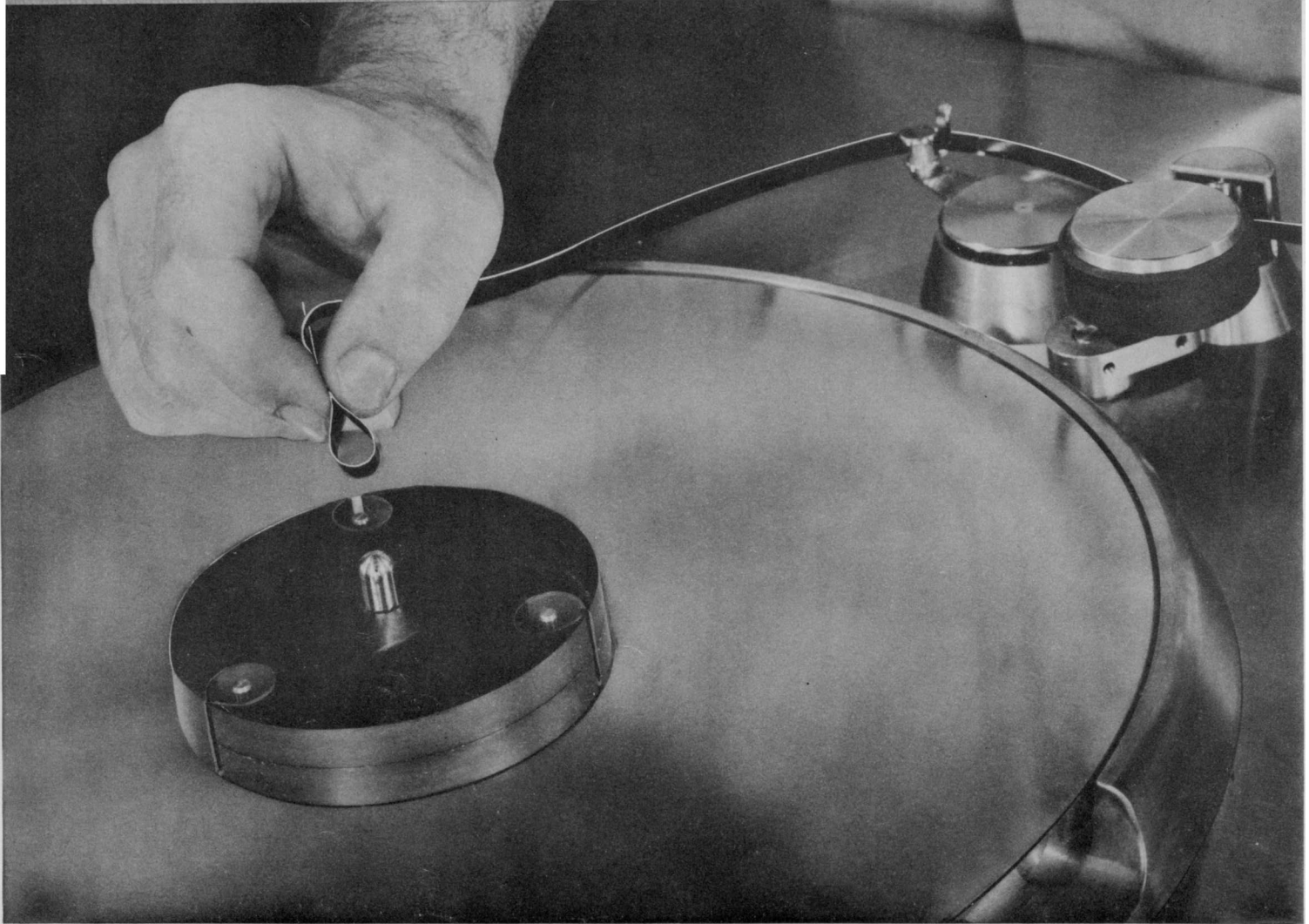

FIGURE 5.

takeup tension arm moved into position, the machine is ready to start. When recording, it is recommended that plenty of leader be used to facilitate cueing and allow for breaking off of the ends.

Due to the fact that some lots of tape have been cut crooked and do not wind properly, it is recommended that when winding at high speed (Rewind or Fast Forward), a cover plate be used on the reel taking up the tape. For this purpose, a flat aluminum disc is provided. This is placed over the empty reel after threading, and is held in place by the editing knob. When a factory wound roll of tape is used, the tape should be played entirely through before rewinding, as the factory winds the tape against the flange and any unused portion will not furnish proper support if tape is wound back on top of it in the machine. It has been found with some tape that if factory wound rolls are immediately wound in Fast Forward, there are kinks and strains in the tape which prevent it from snugging up tight and therefore produce a very loose, unsatisfactory wind. Usually by the time such rolls are rewound once or twice these strains are relieved and the tape will pack properly. Playing through the roll in normal playing position also produces a satisfactory pack.

To facilitate editing, knobs have been provided to use on each reel so that sections of tape can be conveniently passed back and forth through the head housing by hand to locate specific points in the program. A plugged hole is provided in the gate in front of the playback head (see Fig. 3), through which a china marking pencil can be inserted to mark the tape. To locate a specific point in the program, the usual procedure is play the tape through and identify the desired spot. This spot is then played through again and the machine stopped as soon as the desired spot is heard. The tape is then turned back by hand, until the spot is right over the playback head, at which point it can be marked. When a great deal of editing has been done, it is recommended that the roll be wound completely through once before storing to eliminate non-uniform tensions in the roll which might cause buckling.

The following procedure has been found to be quite satisfactory for cueing. The first note of the program is placed over the playback head as described above. A mark is then made on the tape reel on the rewind side opposite some reference point such as the finger recess in the guard plate. The reel is then wound back three complete revolutions, which with a full reel allows about five seconds cueing time. The machine is then started, and the time until the program starts measured with a stopwatch or any convenient second hand. The time is noted, and the program then reset in the same manner. The start button is then depressed at the measured time interval before it is desired to start the program. The above procedure is independent of the individual starting time of the machine. Since the machine comes up to full speed in approximately two seconds, five seconds pre-start time has been found quite satisfactory.

To place two machines in synchronism, the machine to be synchronized is started slightly ahead of the one carrying the program. The Stop and Start buttons are then operated in rapid succession, which cause the machine to drop slightly behind. This is done until the two are in perfect synchronism. In the event the machine is accidentally dropped too far behind, place in Fast Forward until it is once more ahead.

ADJUSTMENTS

All adjustments have been made at the factory for the correct values, and, with the exception of record and playback gain, should not be altered unless damage in

shipment or changing conditions indicate that changes are necessary. Adjustments should be made only by competent technicians, and only with the proper tools and instruments to insure that optimum conditions can be obtained.

ELECTRICAL:

RECORD CHASSIS:

1. R321, Record gain. Set to give optimum performance at line level of plus 4 VU. To set record level for any other value, record desired level at approximately 1,000 cycles. Adjust record gain until playback is plus 4 dbm.

2. R320, Low Frequency Equalization. Set for flat overall response.

3. R319, High Frequency Equalization. Set for flat overall response.

4. R323, Erase Current. Set at maximum.

5. C319, Erase Current Trimmer. Set for minimum erased tape noise. With this trimmer properly tuned, and with the record head disconnected, the erased tape noise should be no greater than the amplifier noise, both audibly and by meter. The character of the tape noise should be a smooth hiss. If the trimmer is improperly tuned, the tape noise will have a "rushy" or roar character and will be considerably higher than the amplifier noise. At the factory the 60 kc. tuning unit has been tuned to bring the oscillator frequency within the range of this trimmer.

6. R322, Bias Current. Set for maximum undistorted signal output. In general, this setting is not critical, once the minimum value is exceeded, which is that value that gives maximum output for constant record input. Increasing the bias above this point does not alter the maximum undistorted signal output, although it takes greater record current to give the same undistorted signal output with higher bias. In general, the bias is set above the point of maximum response (15 to 20 milliamps), to insure that it will never drift into the region of distortion. The bias current can be measured by inserting a 10-ohm resistance in series with the return lead from the record head and measuring the voltage across it with a vacuum tube voltmeter. Thus one side of the meter is at ground potential.

7. C317 and C318, Bias Current Trimmers. These trimmers are set for minimum tape noise when the record head is connected and recording zero signal. When properly set, the tape noise should be only slightly greater than when the record head is disconnected, and the nature of the sound should be a smooth hiss. It will sometimes be found that these trimmers will not tune out the tape noise if the bias current is too low.

PLAYBACK AMPLIFIER:

8. R429, Playback Gain. Set for -6 dbm. output from standard tape, or for gain of unity through the system, so that when making an A-B test, levels are matched (plus 4 VU output with 16 db. pad). For any other level below 20 VU, insert proper pad in the gutter. R323 may be used as a fine adjustment, but should not be set to exceed 20 VU output with a zero loss pad.

9. R431, Low Frequency Equalization. Set at minimum.

10. R430, High Frequency Equalization. Set for flat overall response using standard tape.

11. C414 and C415, 60 kc. Wave Trap. Set to eliminate 60 kc. from output of playback amplifier.

RELAY CHASSIS:

12. R201; Adjusts holdback voltage on rewind or takeup motor during Fast Forward and Rewind, respectively. Set for 30 volts.
13. R202; Adjusts voltage on takeup motor during normal playing. Set for motor voltage of 65-70 volts (60-65 volts with Bodine motors).
14. R203; Adjusts voltage on rewind motor during normal playing. Set for motor voltage of 60-65 volts (55-60 volts with Bodine motors).
15. R205; Adjusts voltage on rewind and takeup motors during rewind and Fast Forward respectively. Set for 90 volts (85 volts on Bodine motors).

MECHANICAL:

1. Brakes. The brakes on the rewind and takeup assemblies are energized by springs, the tension in which can be adjusted by turning the locknut on the bolt to which the spring is anchored. The brake adjustment is pointed out in Fig. 1 and Fig. 7. The brakes are set for 16 ounces pull on an empty reel hub (24. oz. in.) in the non-energizing direction and 32 ounces pull in the energizing direction. The most severe check on the brakes is to stop the machine just after it has come up to speed when starting to fast wind a full roll of tape. This is the point at which there is the greatest tendency to produce slack because of the large mass of the unwinding reel. It may sometimes be found necessary to tighten the brake on the rewind side slightly greater than the above figures to prevent slack from forming at this point.

2. Capstan Tilt Adjustment. The drive assembly plate is attached to the main base plate at three points, two of the points being anchored on spherical surfaces and the third being spring loaded to allow vertical motion. The spring loaded one is the one on the right hand side when facing the drive assembly, and is pointed out in Fig. 2. Turning the locknut on this side adjusts the tilt of the drive assembly. This adjustment has been made to provide optimum tracking of the tape through the drive system. When properly aligned, straight tape should wind in the middle of the reel hub $1/16$ inches above the reel flange. If changes in this adjustment are made, the alignment of the playback head should be re-checked, as the angle at which the tape passes over the playback head may be affected. The record head is not affected by this adjustment.

3. Capstan Idler Pressure Adjustment. The shaft to which the capstan idler arm is attached is held in a clevis below the mounting plate, as may be seen in Fig. 6. Loosening the clevis as shown in Fig. 2 allows the arm to be rotated. To make this adjustment, the idler is held firmly against the capstan at the same time that the solenoid is seated, and the clevis tightened at this point. Care must be taken to insure that the solenoid is seated. On machines of serial numbers 1 to 22, inclusive, the solenoids have a double winding, and seating the solenoid disconnects one of the windings. If the pull-in winding is allowed to remain on, the solenoid will draw excessive current and overheat. The capstan idler must be firmly clamped against the capstan shaft during playing, or the system will be seriously subject to disturbances on the rewind reel, tension arm, or idler.

4. Head Alignment. The record and playback heads are critically aligned at the factory so that recordings may be played back on different machines without affecting the high frequency response. In general, it is recommended that the head alignment be left to the factory, where proper instruments and techniques insure proper alignment.

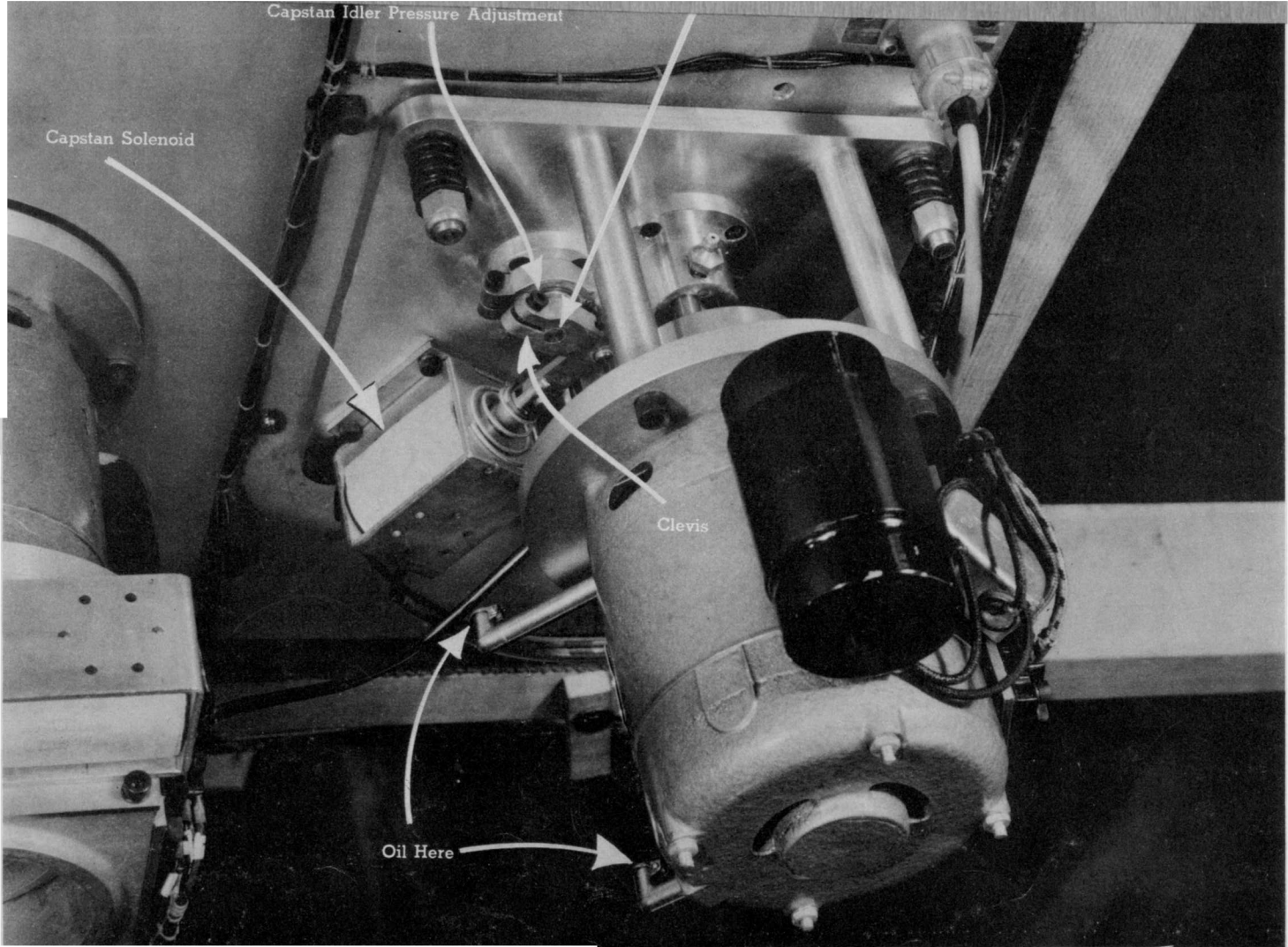

Capstan Idler Pressure Adjustment

Capstan Solenoid

Clevis

Oil Here

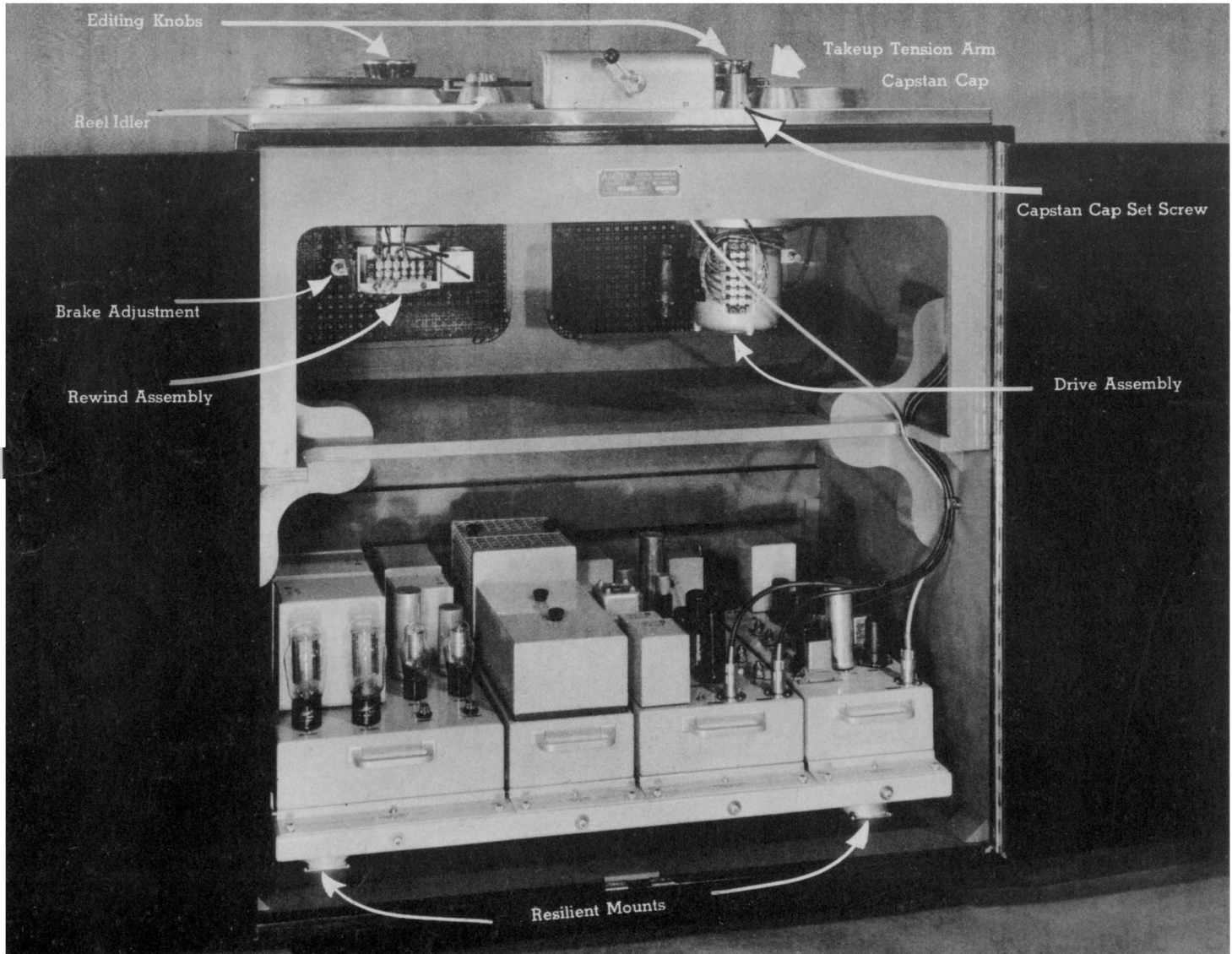

FIGURE 2

However, if for special applications it is desired to change the head alignment, the procedure for realignment is outlined below.

Remove the name plate in the top of the head housing. The record and playback heads are tilted by turning the right hand locknut for each head. The heads are aligned from a standard tape which has been recorded with a head the gap of which has been critically aligned perpendicular to the axis of the tape. The standard tape is recorded at a signal level 10 db. below peak meter reading with the following sequence of frequencies, each lasting for a duration of approximately 10 seconds. Each frequency is preceded by a corresponding number of taps to point out the number of thousands, hundreds, or tens of cycles, which can readily be observed if the output of the machine is fed into a monitoring system as well as a meter.

15,000	1,000
14,000	700
13,000	500
12,000	300
11,000	200
10,000	100
8,000	70
5,000	50
2,000	30

The procedure is to play the standard tape and adjust the playback head for maximum response at one of the highest frequencies. The response should be observed over the entire upper range for uniformity, as it is possible to obtain a maximum on a multiple wave length of a single frequency which will cause dips at other frequencies. After the playback head has been properly aligned, insert a blank tape and record a high frequency of 12,000 to 15,000 cycles and align the record head for maximum playback response. Sweep back and forth with the oscillator to check other frequencies. When making frequency response checks, use an input level of 10 db. below peak meter reading (—6 dbm. for factory adjusted machine). Otherwise, the tape will be overloaded at the high frequencies because of the pre-emphasis characteristic of the record current.

If it becomes necessary to play material recorded with a head that is not in alignment with the AMPEX machine, the playback head can be tilted for maximum high frequency response. This is generally quite satisfactorily accomplished by ear. To realign the playback head with the record head, record a high frequency run and align the playback head for maximum response as described above. It is recommended that the record head never be tilted if it is possible to avoid it, as this can be retained as the standard of alignment.

MAINTENANCE

The following maintenance schedule is recommended:

A. DAILY:

1. Inspect surfaces of heads to make sure that they are clear of any deposit. The region adjacent to the gap should show a high polish. Heads may be cleaned with a toothbrush or similar brush, using carbon tetrachloride or alcohol. To allow greater accessibility to the heads, the gate can be opened wider by simply pushing forward with the fingers when in the open position.

2. Check levels. This may be done by recording a standard tone of 1,000 cycles, and observing the output level. If convenient, a frequency response run can also be made at this time. For a frequency run, the input level should be 10 db. below standard level to prevent overloading the tape at the high frequencies.

3. Check quality. This is done by making an A-B test (that is, comparing the output of the recorder with the program being fed in).

The above checks will rapidly show that all amplifiers and tubes are properly functioning and are in adjustment.

B. WEEKLY:

1. Inspect and clean all glass tape guide surfaces (on tension arms and head housing gate). Free of any deposits left by the tape by washing with a cleansing tissue moistened with alcohol.

2. Remove any accumulation of dust or tape fragments within the head housing gate or around the gate slide.

3. On machines which have Electric Indicator Co. drive motors, lubricate drive motor bearings by filling oil cups provided with Lubriplate No. 4 oil (See Fig. 6).

C. EVERY THREE MONTHS (500 running hours):

1. Lubricate capstan shaft bearings by the application of a small Alemite hand gun to the fitting provided (See Fig. 2). Use only Lubriplate No. 105 grease, Fisk Brothers Refining Company, Newark, New Jersey. Pump gun until grease discharge appears at pressure relief hole near Alemite fitting. This procedure applies to all recorders beginning with Serial No. 21. For all recorders with serial numbers preceding No. 21, the capstan shaft bearings are lubricated by filling the oil cup provided with Lubriplate No. 4 Oil, Fisk Brothers Refining Company.

2. Lubricate Bodine drive motor bearings by filling oil cups provided, using Lubriplate No. 4 oil.

3. Using Lubriplate No. 105 Grease applied with an applicator stick or toothpick, lubricate brake arm bearings and pins. (See Fig. 1.)

4. Remove capstan wiping pad and clean by brushing with a toothbrush. When it is necessary to replace the felt pad because of wear, the pad and the spring to which it is cemented must be replaced as a unit. For the purposes of cleaning or replacement, loosen capstan cap set screw (Fig. 7), rotate cap clockwise as far as possible and remove flat head screws holding wiper spring clamp.

D. GENERAL:

Ball bearings are located in the rewind and takeup motors, reel idler and capstan idler assemblies. These are lubricated for the life of the bearings. Under normal conditions of operation these bearings should give several years of acceptable operating life. Time for their replacement will be indicated by their noise level in operation.

The setting of the brakes should be checked from time to time, as they have a slight tendency to tighten up as the felt linings wear in.

DEMAGNETIZING HEADS

Heads are thoroughly demagnetized before the machine leaves the factory. Every precaution has been taken in the design of the equipment to insure that the heads will not become magnetized in normal operations. However, there are some unusual conditions such as applying an ohmmeter to the heads to measure their resistance, which will

magnetize them. Magnetization produces an excessive noise level on playback, the noise being markedly different than the smooth hiss of normal tape noise and being considerably greater than the amplifier noise level.

Demagnetizing the heads is most simply achieved by applying 60 cycle current through a resistor from a variac, using an ammeter to measure the current. The variac is turned up until the current reads the value specified below, where it is left for a brief instant, and then slowly reduced to zero. **THE SPECIFIED VALUES OF CURRENT CAN BE APPLIED ONLY FOR A BRIEF PERIOD OF TIME, NOT TO EXCEED TWO SECONDS.** About 5 seconds is sufficient for the gradual falling off period.

Maximum 60 cycle demagnetizing currents:

Playback Head	0.2 amperes
Record Head	1.0 amperes
Erase Head	2.0 amperes

PARTS LIST — POWER SUPPLY CHASSIS

SCHEM. REF. NO.	DRAWING OR SPEC. NO.	DESCRIPTION	MFR'S. CAT. OR TYPE NO.
C101		Solar dual 40 mf., 450 V. Electrolytic Condenser.....	DO-2x40-450
C102		Solar dual 40 mf., 150 V.	DO-2x40-150
F101		Littlefuse 2 amp., 250 V. fuse	AGC2
F102		Same as F101	AGC2
J101P		Cannon Connector	DPD-20-34P
L101		Langevin 15 henry, 200 m.a. choke.....	L-1074
L102		Langevin 15 henry, 150 m.a. choke.....	L-1075
L103		Langevin 30 henry, 60 m.a. choke.....	L-1076
R101		50,000 ohm, 5 watt wirewound resistor.....	
R102		500 ohm, 5 watt wirewound resistor.....	
R103		Allen-Bradley 100,000 ohm, 1 watt composition resistor.....	
R104		Allen-Bradley 47,000 ohm, 1 watt composition resistor.....	
T101		Langevin Plate Supply Transformer.....	L-1072
T102		Langevin D.C. filament and relay supply transformer.....	L-1073
V101		5U4 Rectifier tube	
V102		Same as V101	
V103		VR-150 Voltage Regulator tube	
V104		Same as V103	

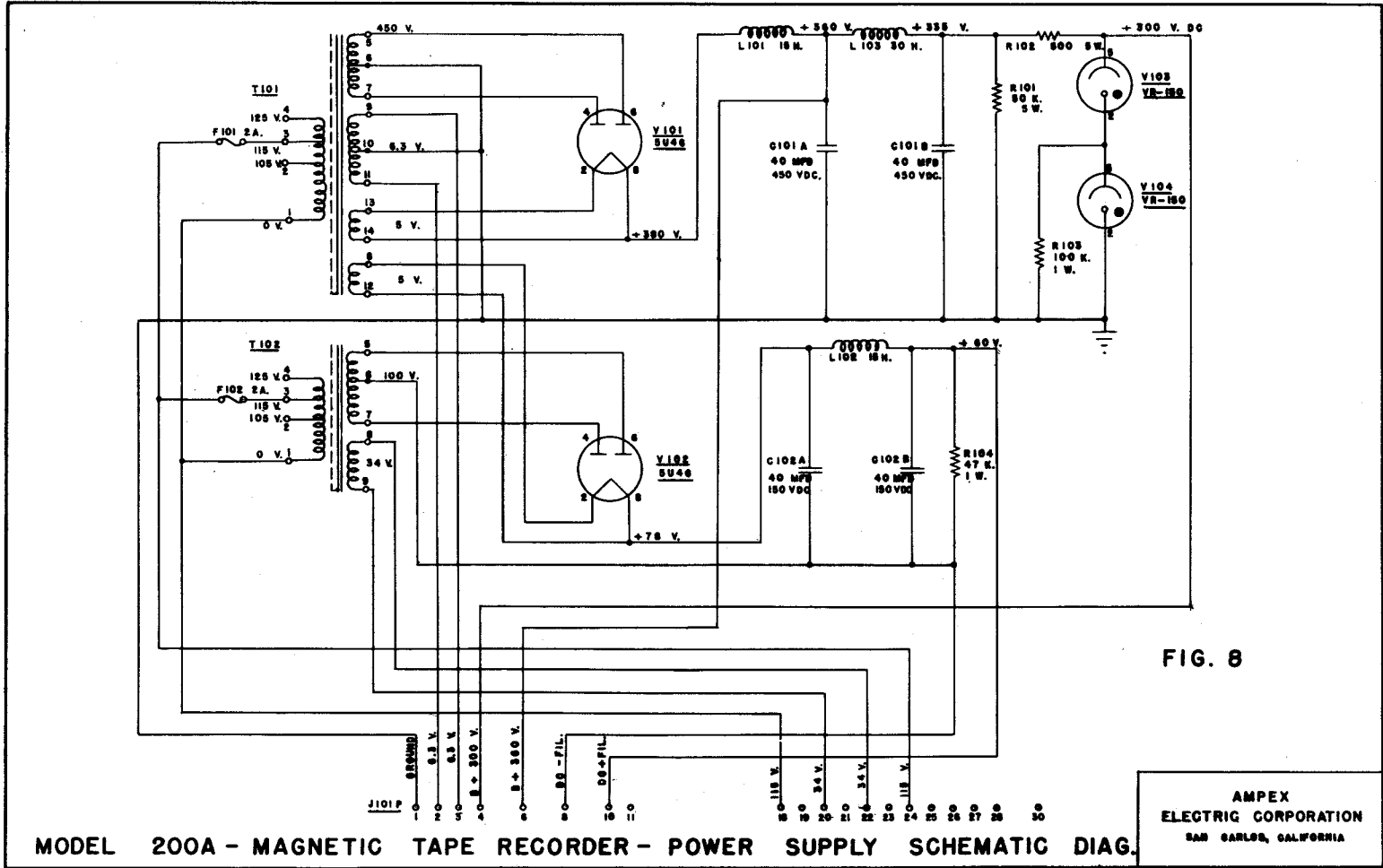

PARTS LIST — RELAY CHASSIS

SCHEM. REF. NO.	DRAWING OR SPEC. NO.	DESCRIPTION	MFR'S. CAT. OR TYPE NO.
C201		.1 mf, 600 V. condenser.....	
C202		Same as C201.....	
C203		Solar 1 mf, 200 V. Solite Condenser.....	SL-2-1M
C204		Solar dual, 80 mf, 50 V. electrolytic condenser.....	DO-2x80-50
C205		Same as C201.....	
CR201		Fansteel Selenium Rectifier, 2.4 amps, 24 V. D.C.....	F 050 M
J201P	EP-285	Howard B. Jones male connector.....	P-315-AB
J201S		Howard B. Jones female connector.....	S-315-AB
J202P		Same as J201P.....	
J202S		Same as J201S.....	
J203P		Same as J201P.....	
J203S		Same as J201S.....	
J204P		Same as J201P.....	
J204S		Same as J201S.....	
J205P	EP-286	Howard B. Jones male connector.....	P-306-AB
J205S		Howard B. Jones female connector.....	S-306-AB
J206P		Cannon Connector.....	DPD-40-34P
K201	EP-285	4 PDT, 24 V. D.C. relay, American Relay and Controls, Inc.....	DO-120-34
K202		Same as K201.....	
K203		Same as K201.....	
K204		Same as K201.....	
K205	EP-286	SPDT, 24 V. D.C. relay.....	Wells' Sales R111
R201		Ohmite 500 ohm, 50 watt, adjustable wirewound resistor.....	0569
R202		Ohmite 100 ohm, 50 watt, adjustable wirewound resistor.....	0565
R203		Same as R202.....	
R204		100 ohm, 1 watt composition resistor, Allen-Bradley.....	
R205		Ohmite 25 ohm, 50 watt, adjustable wirewound resistor.....	0562
		<i>with Bodine Motors:</i>	
R201		Ohmite 200 ohm, 50 watt, adjustable wirewound resistor.....	0567
R202		Ohmite 50 ohm, 50 watt adjustable wirewound resistor.....	0563
R203		Same as R202.....	
R205		15 ohm, 50 watt adjustable wirewound resistor.....	

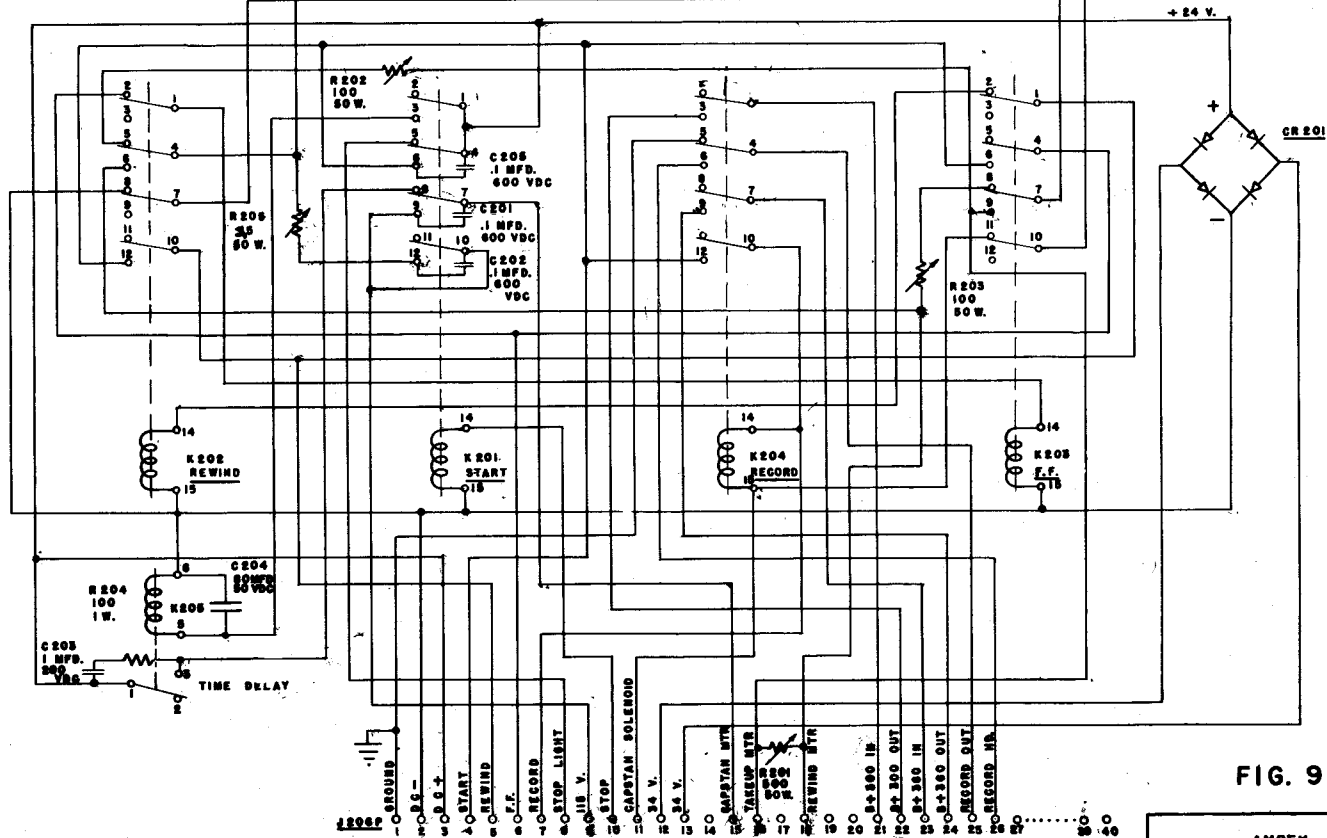

MODEL 200A - MAGNETIC TAPE RECORDER-RELAY CHASSIS SCHEMATIC DIAG.

FIG. 9

AMPEX
ELECTRIC CORPORATION
SAN CARLOS, CALIFORNIA

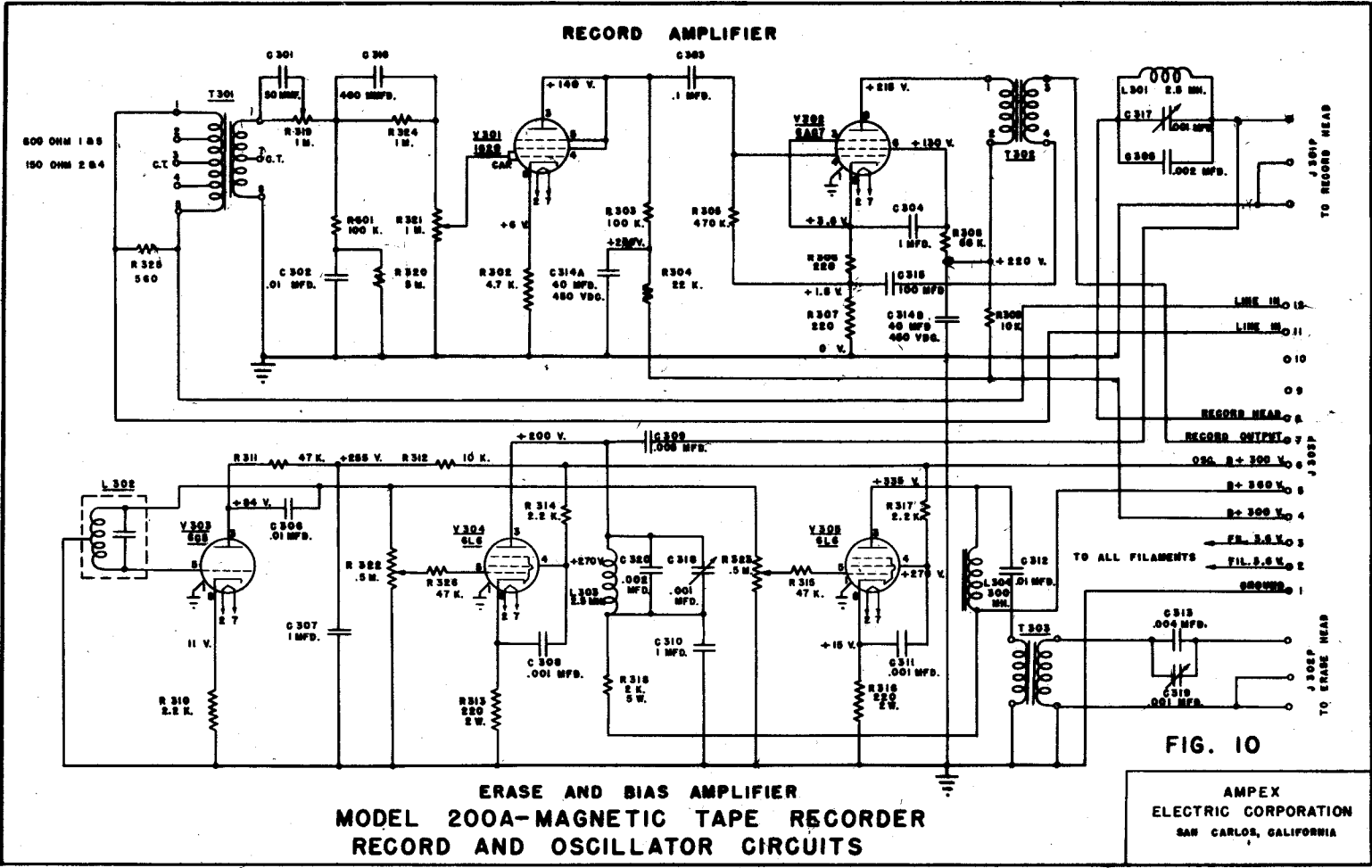

PARTS LIST — RECORD AMPLIFIER

SCHEM. REF. NO.	DRAWING OR SPEC. NO.	DESCRIPTION	MFR'S. CAT. OR TYPE NO.
C301		50 mmf, 500 v. Mica Condenser, 5% tolerance.....	
C302		.01 mf, 200 v. Tubular Condenser, 5% tolerance.....	
C303		.1 mf, 600 v. Tubular Condenser.....	
C304		G. E. 1 mf, 600 v. Pyronal Condenser.....	23F326
C305		.002 mf, 500 v. Mica Condenser, 5% tolerance.....	
C306		.01 mf, 600 v. Tubular Condenser.....	
C307		Same as C304.....	
C308		.001 mf, 500 v. Mica Condenser.....	
C309		.005 mf, 500 v. Mica Condenser, 5% tolerance.....	
C310		Same as C304.....	
C311		Same as C308.....	
C312		Same as C306.....	
C313		.004 mf, 500 v. Mica Condenser, 5% tolerance.....	
C314		Solar Dual 40 mf, 450 v. Electrolytic Condenser—Same as C101.....	DO-2x40-450 DO - 100 - 25
C315		Solar 100 mf, 25 v. Electrolytic Condenser.....	
C316		400 mmf., 500 v. Mica Condenser.....	
C317		.001 mf Padder Condenser—El Menco.....	#306 Type 30
C318		Same as C317.....	
C319		Same as C317.....	
C320		Same as C305.....	
J301P		Cannon Receptacle	XL - 3 - 14
J302P		Same as J301.....	
J303P		Cannon Connector	DP-B-12-34P
L301		Miller 2.5 m.h. Choke.....	640
L302		Lenkurt 60 k.c. Tuning Unit.....	P1370-60 K.C.
L303		Same as L301.....	
L304		Langevin 300 mf, 60 k.c. Choke.....	L-1077
R301		100,000 ohm, 1 watt, Composition Resistor, Allen-Bradley, same as R103.....	
R302		4700 ohm, 1 watt, Composition Resistor, Allen-Bradley.....	
R303		Same as R301.....	

PARTS LIST — RECORD AMPLIFIER, continued

SCHEM. REF. NO.	DRAWING OR SPEC. NO.	DESCRIPTION	MFR'S. CAT. OR TYPE NO.
R304		22,000 ohm, 1 watt, Composition Resistor, Allen-Bradley.....	
R305		.47 megohm, 1 watt, Composition Resistor, Allen-Bradley.....	
R306		220 ohm, 1 watt, Composition Resistor, Allen-Bradley.....	
R307		Same as R306.....	
R308		68,000 ohm, 1 watt, Composition Resistor, Allen-Bradley.....	
R309		10,000 ohm, 1 watt, Composition Resistor, Allen-Bradley.....	
R310		2200 ohm, 1 watt, Composition Resistor, Allen-Bradley.....	
R311		47,000 ohm, 1 watt, Composition Resistor, Allen-Bradley, same as R104.....	
R312		Same as R309.....	
R313		220 ohm, 2 watt, Composition Resistor, Allen-Bradley.....	
R314		Same as R310.....	
R315		Same as R311.....	
R316		Same as R313.....	
R317		Same as R310.....	
R318		2000 ohm, 5 watt, Wirewound Resistor.....	
R319		1 megohm Potentiometer, Ohmite Type AB, Clockwise Log Taper.....	CA 1052
R320		5 megohm Potentiometer, Ohmite Type AB, Linear Taper.....	CU 5052
R321		Same as R319.....	
R322		.5 megohm Potentiometer, Ohmite Type AB, Clockwise Log Taper.....	CA 5041
R323		Same as R322.....	
R324		1 meg, 1 watt, Composition Resistor, Allen-Bradley.....	
R325		560 ohms, 1 watt Composition Resistor, Allen-Bradley.....	
R326		Same as R311.....	
T301		Langevin Line to Grid Transformer.....	L-1078
T302		Langevin Plate to Head Transformer.....	L-1080
T303		Langevin 60 k.c. Erase Transformer.....	L-1081
V301		1620 Vacuum Tube.....	
V302		6AC7 Vacuum Tube.....	
V303		6C5 Vacuum Tube.....	
V304		6L6 Vacuum Tube.....	
V305		Same as V304.....	

PARTS LIST — PLAYBACK AMPLIFIER

SCHEM. REF. NO.	DRAWING OR SPEC. NO.	DESCRIPTION	MFR'S. CAT. OR TYPE NO.	
C401		Solar 1 mf, 200 v. Solite Condenser, same as C203.....	SL-2-1M 23F326	
C402		G. E. 1 mf, 600 v. Pyronol Condenser, same as C304.....		
C403		.05 mf, 400 v. Tubular Condenser.....		
C404		.02 mf, 200 v. Tubular Condenser, 5% tolerance.....		
C405		Same as C402.....		
C406		Same as C403.....		
C407		Same as C402.....		
C408		Same as C403.....		
C409		.003 mf, 500 v. Mica Condenser.....		
C410		.002 mf, 500 v. Mica Condenser, 5% tolerance, same as C305.....		
C411		.005 mf, 500 v. Mica Condenser, 5% tolerance, same as C309.....		
C412		.1 mf, 600 v. Tubular Condenser, same as C303.....		
C413		Same as C412.....		
C414		100 mf, Air Trimmer Condenser.....		Radio Surplus Corp 235
C415		Same as C414.....		
C416		100 mf, 25 v. Electrolytic Condenser.....	DO-2x40-450 DO-3x20-450	
C417		Solar Dual 40 mf, 450 v. Electrolytic Condenser, same as C101.....		
C418		Solar Triple 20 mf, 450 v. Electrolytic Condenser.....		
C419		Same as C409.....	XL-3-14 DP-B-12-34P 960	
J401P		Cannon Receptacle, same as J301.....		
J402P		Cannon Connector, same as J303.....		
L401		Miller 100mh. Iron Core Choke.....		
L402		Same as L401.....		
R401		1 megohm, 1 watt, composition resistor, Allen-Bradley, same as R324.....		
R402		1000 ohm, 1/2 watt, non-inductive precision wirewound resistor.....		
R403		300,000 ohm, 1/2 watt, non-inductive precision wirewound resistor.....		
R404		10,000 ohm, 1 watt, composition resistor, Allen-Bradley, same as R309.....		

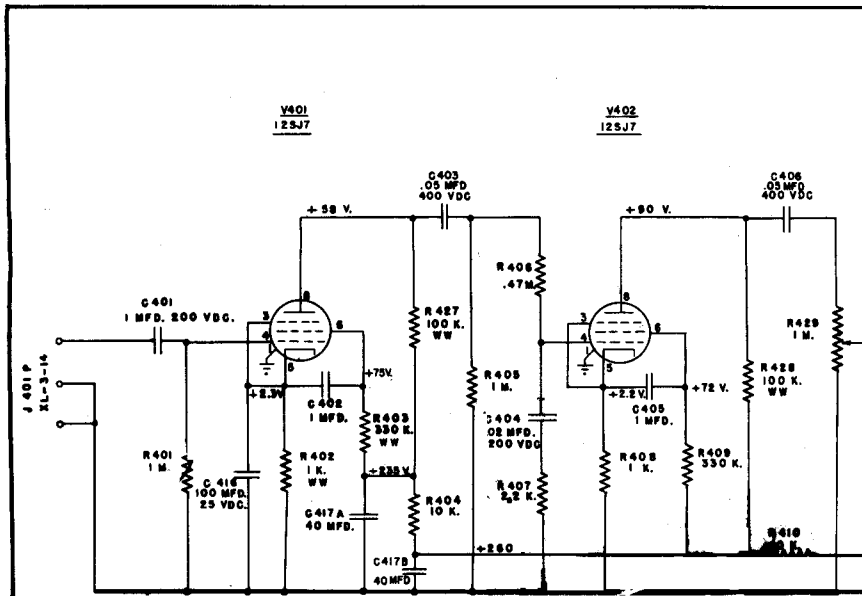
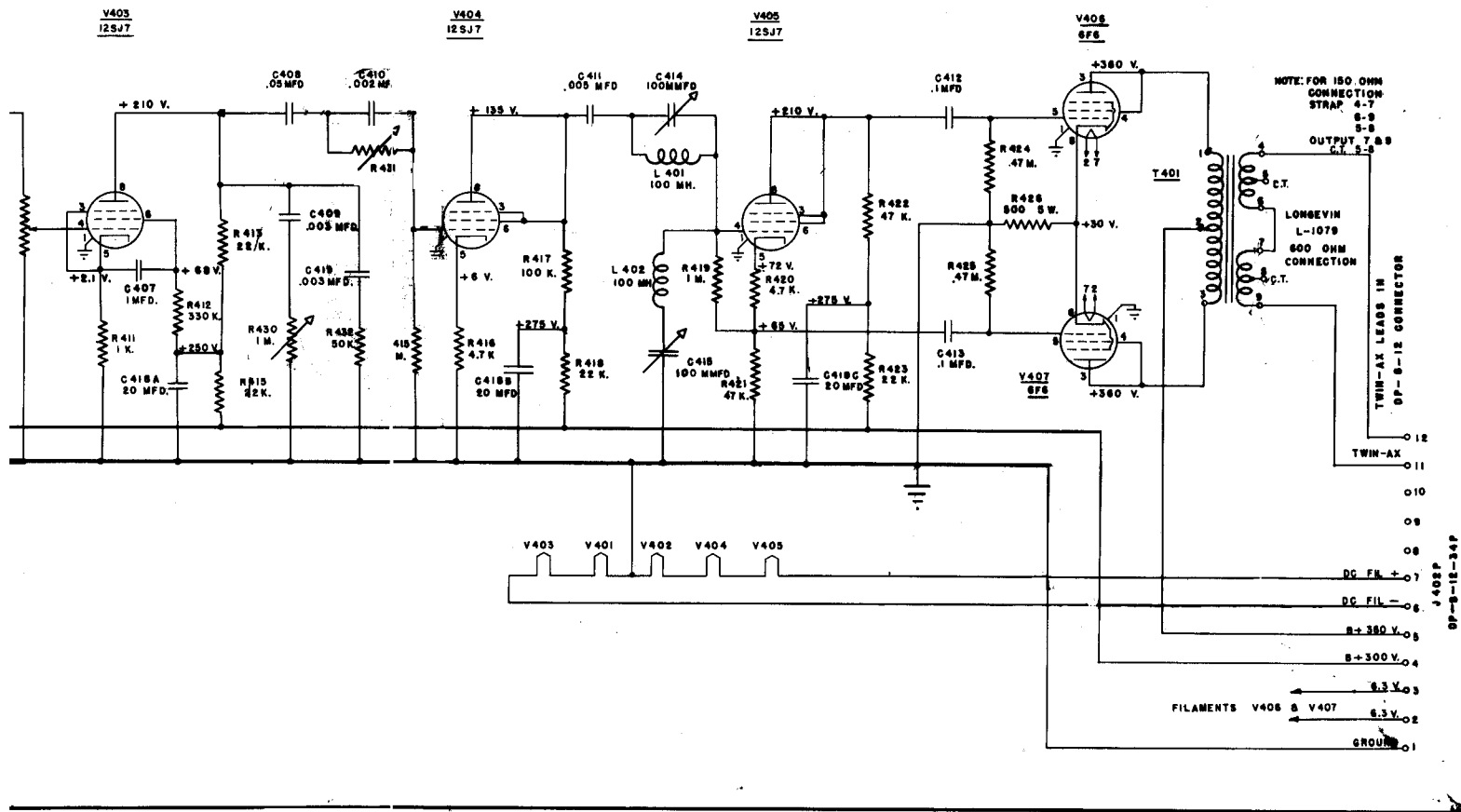

FIG. II

MODEL 200A-MAGNETIC TAPE RECORDER
PLAYBACK AMPLIFIER SCHEMATIC DIAG.

AMPEX
ELECTRIC CORPORATION
SAN CARLOS, CALIFORNIA



J40EP
DP-8-12-34P

PARTS LIST — PLAYBACK AMPLIFIER, continued

SCHEM. REF. NO.	DRAWING OR SPEC. NO.	DESCRIPTION	MFR'S. CAT. OR TYPE NO.
R405		Same as R401.....	
R406		.47 megohm, 1 watt, composition resistor, Allen-Bradley, same as R305.....	
R407		2200 ohm, 1 watt, composition resistor, Allen-Bradley, 5% tolerance.....	
R408		1000 ohm, 1 watt, composition resistor, Allen-Bradley.....	
R409		330,000 ohm, 1 watt, composition resistor, Allen-Bradley.....	
R410		Same as R404.....	
R411		Same as R408.....	
R412		Same as R409.....	
R413		22,000 ohm, 1 watt, composition resistor, Allen-Bradley, same as R304.....	
R414		Same as R413.....	
R415		Same as R401.....	
R416		4700 ohm, 1 watt, composition resistor, Allen-Bradley, same as R302.....	
R417		100,000 ohm, 1 watt, composition resistor, Allen-Bradley, same as R103.....	
R418		Same as R413.....	
R419		Same as R401.....	
R420		Same as R416.....	
R421		47,000 ohm, 1 watt, composition resistor, Allen-Bradley, same as R104.....	
R422		Same as R421.....	
R423		Same as R413.....	
R424		Same as R406.....	
R425		Same as R406.....	
R426		500 ohm, 5 watt wirewound resistor, same as R102.....	
R427		100,000 ohm, 1/2 watt, non-inductive precision wirewound resistor.....	

PARTS LIST — PLAYBACK AMPLIFIER, continued

SCHEM. REF. NO.	DRAWING OR SPEC. NO.	DESCRIPTION	MFR'S. CAT. OR TYPE NO.
R428		Same as R427.....	
R429		1 megohm potentiometer, ohmite type AB, clockwise log taper, same as R319.....	CA1052
R430		Same as R429.....	
R431		5 megohm potentiometer, ohmite type AB, linear taper, same as R320.....	CU5052
R432		Same as R421.....	
T401		Langevin transformer push-pull 6F6's to line.....	L-1079
V401		12SJ7 vacuum tube.....	
V402		Same as V401.....	
V403		Same as V401.....	
V404		Same as V401.....	
V405		Same as V401.....	
V406		6F6 vacuum tube.....	
V407		Same as V406.....	

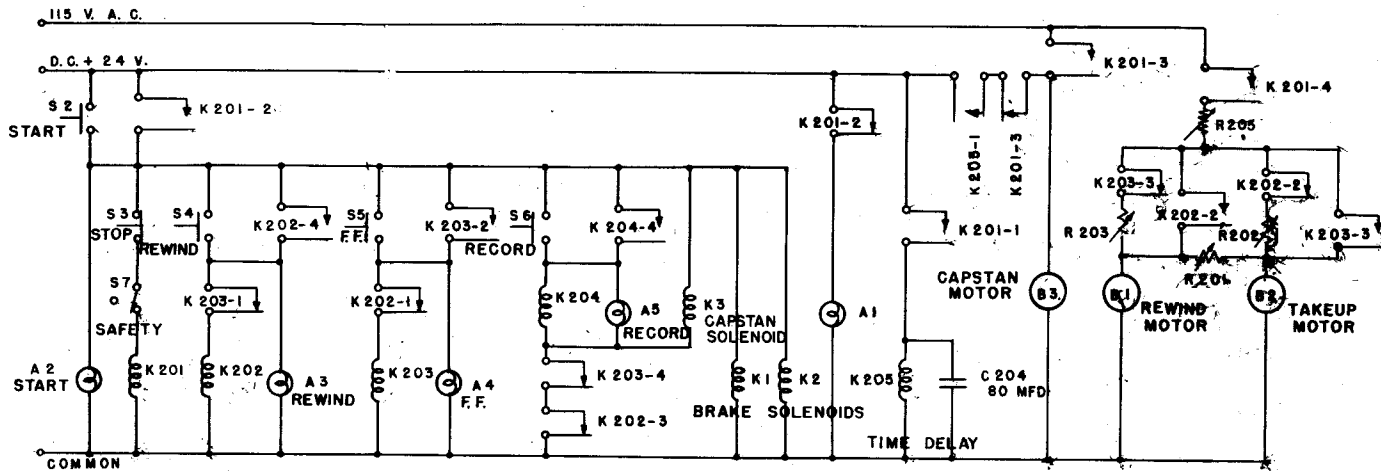

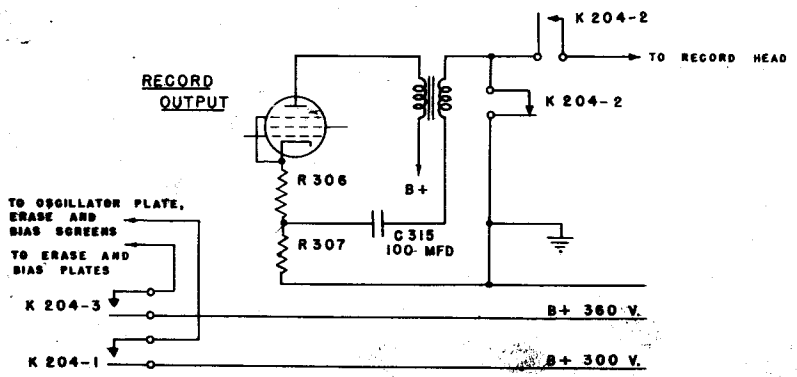

34

FIG. 12



LEGEND:

-  K201 OPERATING COIL, RELAY K 201
-  K202-1 NORMALLY CLOSED CONTACT NO. 1, RELAY K 202
-  K203-2 NORMALLY OPEN CONTACT NO. 2, RELAY K 203

MODEL 200 A - MAGNETIC TAPE RECORDER - SCHEMATIC CONTROL DIAG.

AMPEX
ELECTRIC CORPORATION
SAN CARLOS, CALIFORNIA

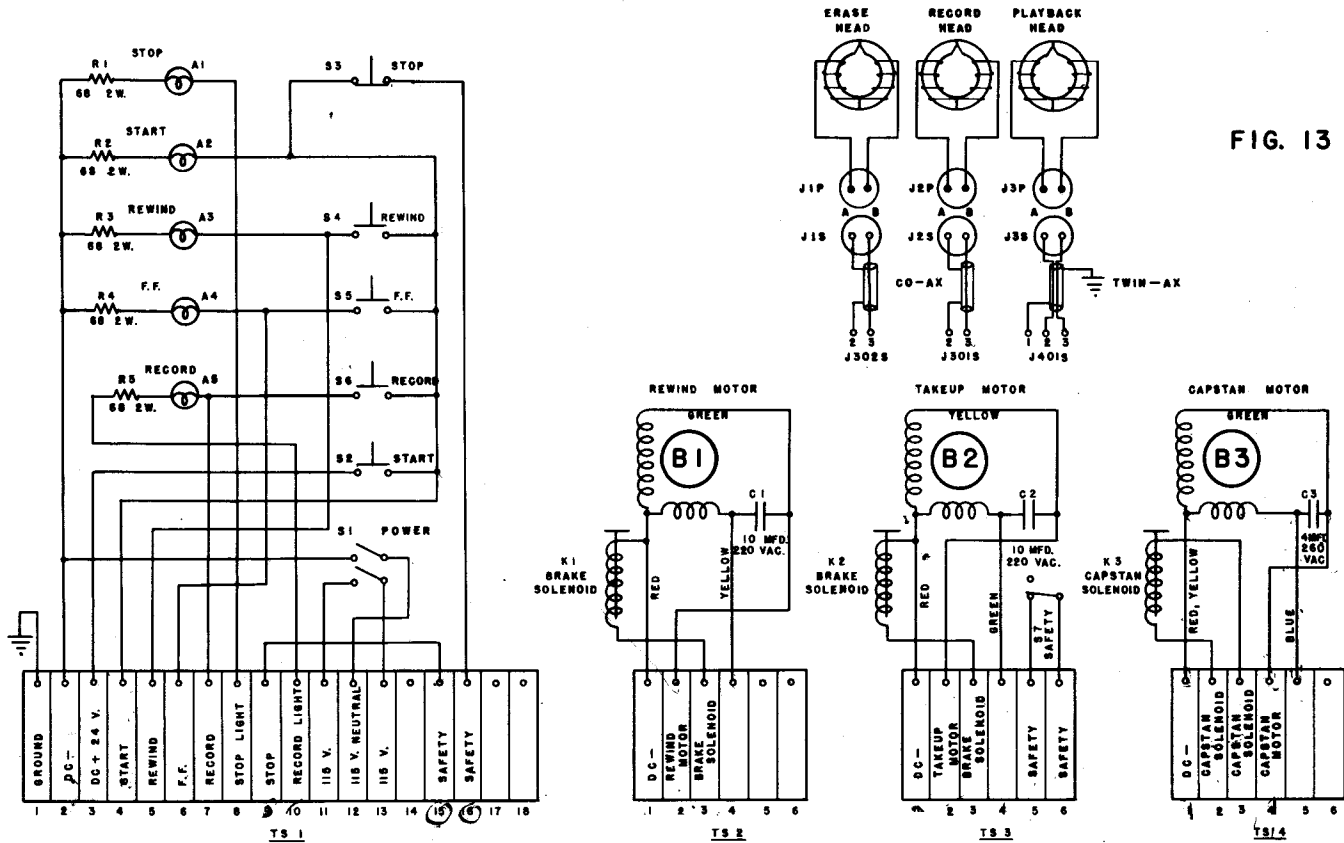

FIG. 13

MODEL 200A - MAGNETIC TAPE RECORDER - TOP PLATE SCHEMATIC DIAG.

AMPEX
ELECTRIC CORPORATION
SAN CARLOS, CALIFORNIA

PARTS LIST — TOP PLATE ASSEMBLY

SCHEM. REF. NO.	DRAWING OR SPEC. NO.	DESCRIPTION	MFR'S. CAT. OR TYPE NO.
A 1		Mazda 28 v. miniature lamp, bayonet base.....	313
A 2		Same as A 1.....	
A 3		Same as A 1.....	
A 4		Same as A 1.....	
A 5		Same as A 1.....	
B 1		Electric Indicator Co. capacitor induction motor, 115 v. A.C., 60 cycles, 1700 r.p.m.....	GFFZD-302
B 2		Same as B 1.....	
B 3		Electric Indicator Co. hysteresis synchronous motor, 1/40 h.p., 1800 r.p.m., 115 v., 60 cycles.....	GKHF-275
C 1		10 mf., 220 v. A.C., motor condenser, General Electric Co.....	21F136
C 2		Same as C 1.....	
C 3		4.0 +11% mf., 260 v. A.C., condenser, Sprague — 0.....	16P-31
J 1 P	A-222	Cannon straight connector less shell coupling nut, and assembly nut, modified.....	AN-3106-14s-9P
J 2 P		Same as J 1 P.....	
J 3 P		Same as J 1 P.....	
J 1 S	A-232	Cannon box mounting unit, modified.....	AN-3102-14s-9S
J 2 S		Same as J 1 S.....	
J 3 S		Same as J 1 S.....	
J301S		Cannon plug.....	XL-3-11
J302S		Same as J301S.....	
J401S		Same as J301S.....	
K 1	A-136	Philtrol actuator, Phillips Control Corporation.....	40C27DC
K 2	A-136	Same as K 1.....	
K 3	A-182	Philtrol Actuator.....	40C27DC
R 1		68 ohm, 2 watt, composition resistor, Allen-Bradley.....	
R 2		Same as R 1.....	
R 3		Same as R 1.....	
R 4		Same as R-1.....	

PARTS LIST — TOP PLATE ASSEMBLY, continued

SCHEM. REF. NO.	DRAWING OR SPEC. NO.	DESCRIPTION	MFR'S. CAT. OR TYPE NO.
R 5		Same as R-1.....	
S 1		Cutler-Hammer 2 pole single throw, 1 h.p., toggle switch.....	7360 K 8
S 2		Acro-Snap push button switch, normally open, Acro Electric Co.....	3NO5-5P
S 3		Acro-Snap push button switch, normally closed, Acro Electric Co.....	3NC5-5P
S 4		Same as S 2.....	
S 5		Same as S 2.....	
S 6		Same as S 2.....	
S 7		Low torque, double throw micro-switch.....	V3-14
TS-1		Howard B. Jones terminal and marker strip.....	18-141-MS
TS-2		Howard B. Jones terminal and marker strip.....	6-141-MS
TS-3		Same as TS-2.....	
TS-4		Same as TS-2.....	
ALTERNATE:			
B 1		Bodine Electric Co. capacitor induction motor, 115 v., 60 cycles, 1700 r.p.m.....	NCI-34
B 3		Bodine Electric Co. synchronous motor, 1/25 h.p., 1800 r.p.m., 115 v., 60 cycles.....	NYC-35
C 1		7.5 mfd., 330 v., A.C., motor condenser, General Electric Co.....	21F128
C 3		5 mfd., 330 v. A.C., motor condenser, General Electric Co.....	21F127
C 4		(Bodine motor only) Same as C 3.....	

PARTS LIST — REMOTE CONTROL PANEL

SCHEM. REF. NO.	DRAWING OR SPEC. NO.	DESCRIPTION	MFR'S. CAT. OR TYPE NO.
A601		Mazda 28 v. miniature lamp, bayonet base.....	313
A602		Same as A601.....	
A603		Same as A601.....	
A604		Same as A601.....	
A605		Same as A601.....	
J601P		Howard B. Jones male connector.....	P-315-AB
R601		68 ohm, 2 watt composition resistor, Allen-Bradley.....	
R602		Same as R601.....	
R603		Same as R601.....	
R604		Same as R601.....	
R605		Same as R601.....	
S601		Acro-Snap pushbutton switch, normally open, Acro Electric Co.....	3NO5-5P
S602		Acro-Snap pushbutton switch, normally closed, Acro Electric Co.....	3NC5-5P
S603		Same as S601.....	
S604		Same as S601.....	
S605		Same as S601.....	

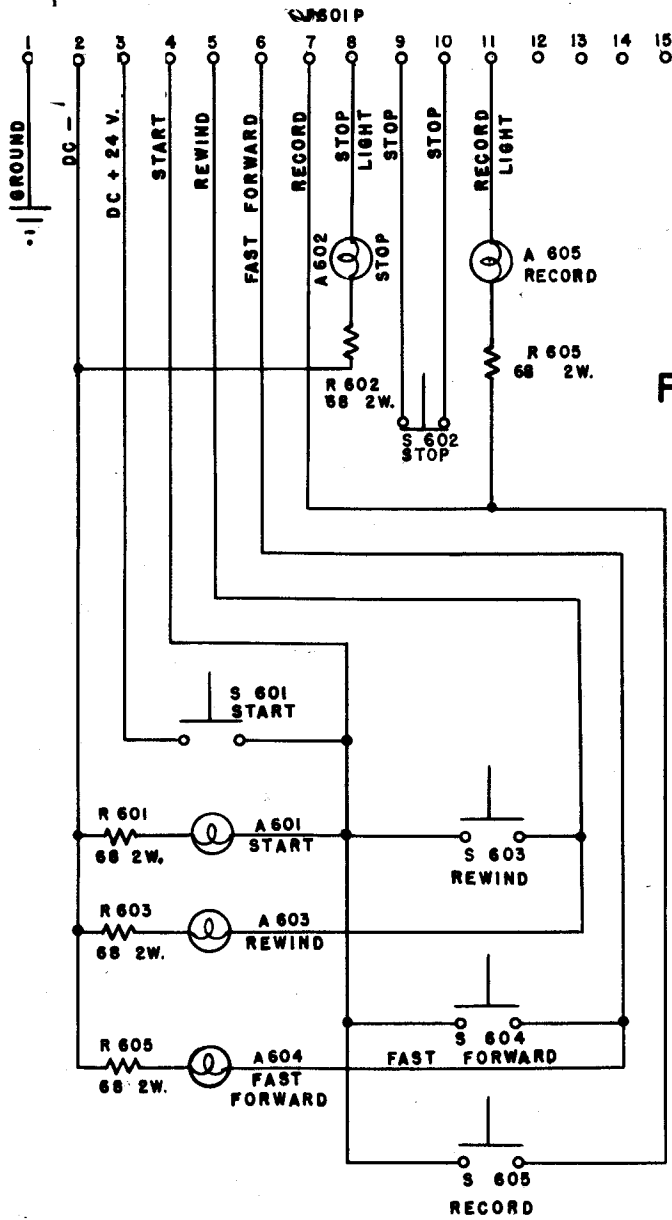

FIG. 14

MODEL 200A
 MAGNETIC TAPE RECORDER
 REMOTE CONTROL PANEL

AMPEX ELECTRIC CORPORATION SAN CARLOS, CALIFORNIA

PARTS LIST — WIRING GUTTER

SCHEM. REF. NO.	DRAWING OR SPEC. NO.	DESCRIPTION	MFR'S. CAT. OR TYPE NO.
F501		Littlefuse 8 ampere fuse, 250 v.....	AGC-8
J101S		Cannon connector	DP-D-20-33S
J206S		Cannon connector	DP-D-40-33S
J303S		Cannon connector	DP-B-12-33S
J402S		Same as J303S.....	
J501P		Hubbell Twist-Lock 10 amperes, 3 wire receptacle, flush base.....	7556
J501S		Hubbell Twist-Lock 10 amperes, 3 wire connector body.....	7555
J502P		Cannon receptacle, same as J301P.....	XL-3-14
J502S		Cannon plug, same as J301S.....	XL-3-11
J503P		Same as J502P.....	
J503S		Same as J502S.....	
J504S		Howard B. Jones female connector, same as J201S.....	S-315-AB
J504P		Howard B. Jones male connector.....	P-315-CCT
J505S		Amphenol Octal socket.....	77-MIP 8
TS501		Howard B. Jones terminal strip.....	5-141
TS502		Howard B. Jones terminal strip.....	10-141
R501		16 db. attenuator—Daven Co. H pad, 600/600 ohms.....	H-691, 16 db.