

HiFi ENGINE®

For more Hi-Fi manuals and set-up information
please visit www.hifiengine.com

OPERATION/MAINTENANCE 5700122801

TASCAM

TEAC Professional Division

BR-20 Series

1/4" 2-Track Recorder/Reproducer



The guarantee provided for the BR-20 has several restrictions. The BR-20 will perform properly only if it is adjusted properly and we guarantee that such adjustment is possible. Setup is not covered by Warranty. If your attempts at internal adjustments are unsuccessful, we will charge you for readjustments.

Recording is an art as well as a science. As a result, your finished product may be judged more by artistic criteria than technical performance. Art is the province of the artist and TASCAM can make no guarantee that the BR-20, *by itself*, will assure the quality of your work.

Your skill as a technician and your abilities as an artist will be significant factors in the results you achieve.

Bescheinigung des Herstellers/Importeurs

Hiermit wird bescheinigt, daß der/die/das

MAGNETTONBANDGERÄT TASCAM BR-20

(Gerät, Typ, Bezeichnung)

in Übereinstimmung mit den Bestimmungen der

AMTSBLATT 163/1984, VFG 1045/1984, VFG 1046/1984

(Amtsblattverfügung)

funk-entstört ist.

Der Deutschen Bundespost wurde das Inverkehrbringen dieses Gerätes angezeigt und die Berechtigung zur Überprüfung der Serie auf Einhaltung der Bestimmungen eingeräumt.

TEAC CORPORATION

Name des Herstellers/Importeurs

THE APPLIANCE CONFORMS WITH EEC DIRECTIVE 87/308/EEC REGARDING INTERFERENCE SUPPRESSION

CONFORME AL D.M. 13 APRILE 1989
DIRETTIVA CEE/87/308



CAUTION
RISK OF ELECTRIC SHOCK
DO NOT OPEN



CAUTION: TO REDUCE THE RISK OF ELECTRIC SHOCK, DO NOT REMOVE COVER (OR BACK). NO USER-SERVICEABLE PARTS INSIDE. REFER SERVICING TO QUALIFIED SERVICE PERSONNEL.



The lightning flash with arrowhead symbol, within an equilateral triangle, is intended to alert the user to the presence of uninsulated "dangerous voltage" within the product's enclosure that may be of sufficient magnitude to constitute a risk of electric shock to persons.



The exclamation point within an equilateral triangle is intended to alert the user to the presence of important operating and maintenance (servicing) instructions in the literature accompanying the appliance.

This appliance has a serial number located on the rear panel. Please record the model number and serial number and retain them for your records.

Model number _____
Serial number _____

WARNING: TO PREVENT FIRE OR SHOCK HAZARD, DO NOT EXPOSE THIS APPLIANCE TO RAIN OR MOISTURE.

SAFETY INSTRUCTIONS

CAUTION:

- Read all of these instructions.
- Save these instructions for later use.
- Follow all warnings and instructions marked on the audio equipment.

1. **Read Instructions** — All the safety and operating instructions should be read before the appliance is operated.
2. **Retain Instructions** — The safety and operating instructions should be retained for future reference.
3. **Heed Warnings** — All warnings on the appliance and in the operating instructions should be adhered to.
4. **Follow Instructions** — All operating and use instructions should be followed.
5. **Water and Moisture** — The appliance should not be used near water — for example, near a bathtub, washbowl, kitchen sink, laundry tub, in a wet basement, or near a swimming pool, etc.
6. **Carts and Stands** — The appliance should be used only with a cart or stand that is recommended by the manufacturer.
- 6A. An appliance and cart combination should be moved with care. Quick stops, excessive force, and uneven surfaces may cause the appliance and cart combination to overturn.



7. **Wall or Ceiling Mounting** — The appliance should be mounted to a wall or ceiling only as recommended by the manufacturer.
8. **Ventilation** — The appliance should be situated so that its location or position does not interfere with its proper ventilation. For example, the appliance should not be situated on a bed, sofa, rug, or similar surface that may block the ventilation openings; or, placed in a built-in installation, such as a bookcase or cabinet that may impede the flow of air through the ventilation openings.
9. **Heat** — The appliance should be situated away from heat sources such as radiators, heat registers, stoves, or other appliances (including amplifiers) that produce heat.
10. **Power Sources** — The appliance should be connected to a power supply only of the type described in the operating instructions or as marked on the appliance.
11. **Grounding or Polarization** — The precautions that should be taken so that the grounding or polarization means of an appliance is not defeated.
12. **Power-Cord Protection** — Power-supply cords should be routed so that they are not likely to be walked on or pinched by items placed upon or against them, paying particular attention to cords at plugs, convenience receptacles, and the point where they exit from the appliance.

13. **Cleaning** — The appliance should be cleaned only as recommended by the manufacturer.
14. **Power Lines** — An outdoor antenna should be located away from power lines.
15. **Outdoor Antenna Grounding** — If an outside antenna is connected to the receiver, be sure the antenna system is grounded so as to provide some protection against voltage surges and built up static charges. Section 810 of the National Electrical Code, ANSI/NFPA No. 70 — 1984, provides information with respect to proper grounding of the mast and supporting structure, grounding of the lead-in wire to an antenna discharge unit, size of grounding conductors, location of antenna-discharge unit, connection to grounding electrodes, and requirements for the grounding electrode. See Figure below.

EXAMPLE OF ANTENNA GROUNDING
AS PER NATIONAL
ELECTRICAL CODE

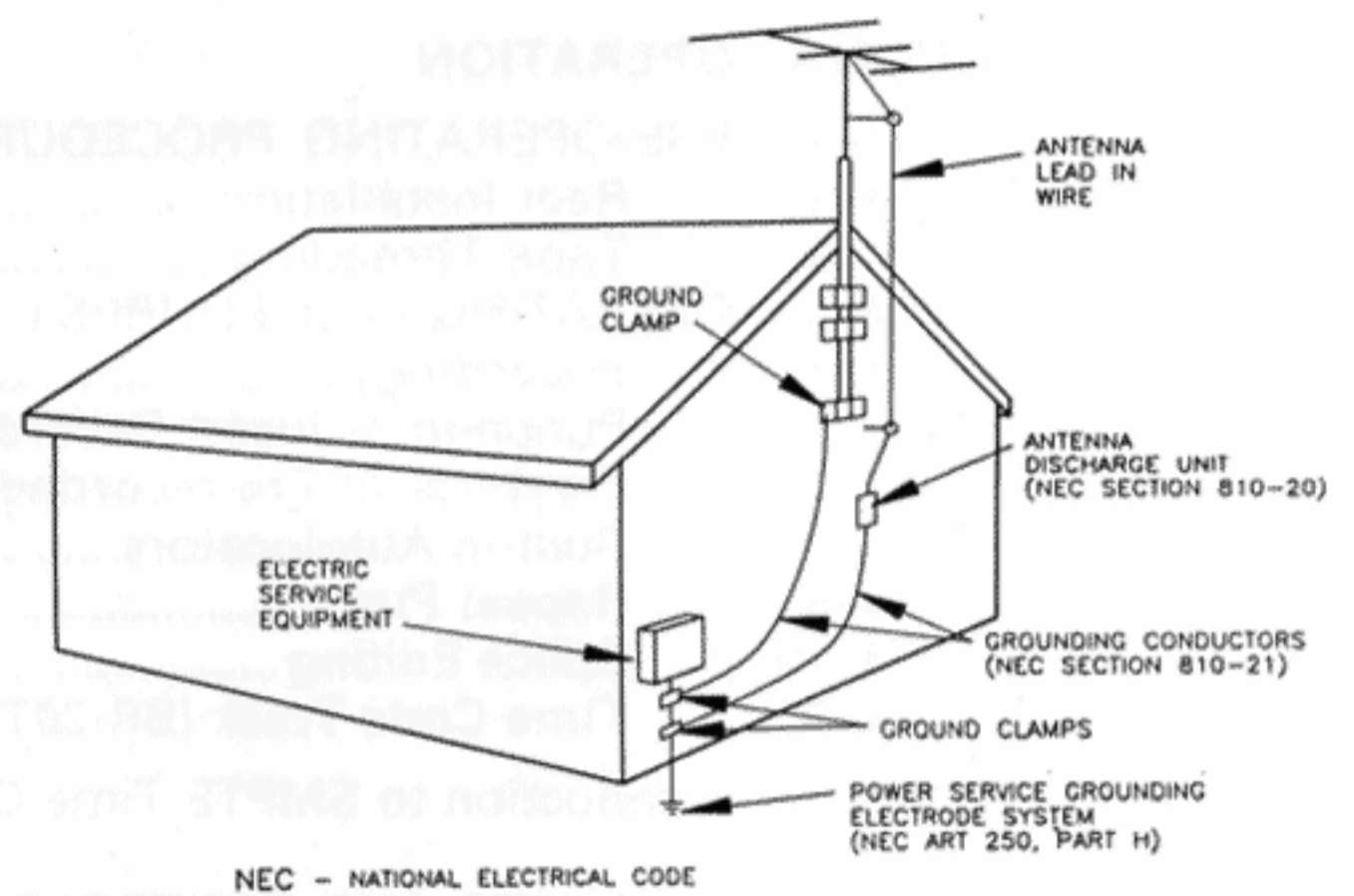

16. **Nonuse Periods** — The power cord of the appliance should be unplugged from the outlet when left unused for a long period of time.
17. **Object and Liquid Entry** — Care should be taken so that objects do not fall and liquids are not spilled into the enclosure through openings.
18. **Damage Requiring Service** — The appliance should be serviced by qualified service personnel when:
 - A. The power-supply cord or the plug has been damaged; or
 - B. Objects have fallen, or liquid has been spilled into the appliance; or
 - C. The appliance has been exposed to rain; or
 - D. The appliance does not appear to operate normally or exhibits a marked change in performance; or
 - E. The appliance has been dropped, or the enclosure damaged.
19. **Servicing** — The user should not attempt to service the appliance beyond that described in the operating instructions. All other servicing should be referred to qualified service personnel.

TABLE OF CONTENTS

	TITLE	PAGE NO.
SECTION 1	GENERAL DESCRIPTION	
1-1.	INTRODUCTION.....	5
1-2.	Memory Back-up Feature.....	5
SECTION 2	SPECIFICATIONS	
2-1.	SPECIFICATIONS.....	6
2-2.	Control Signal Block Diagram.....	9
2-3.	Audio Signal Block and Level Diagrams.....	10
SECTION 3	INSTALLATION	
3-1.	UNPACKING AND INSPECTION.....	11
3-2.	OPTIONAL MODIFICATIONS.....	12
3-3.	INSTALLATION SITE.....	12
3-4.	Rack Mounting the BR-20.....	13
3-5.	INITIAL CONNECTIONS.....	13
SECTION 4	OPERATION	
4-1.	PRE-OPERATING PROCEDURES.....	14
4-2.	Reel Installation.....	14
4-3.	Tape Threading.....	14
4-4.	OPERATING PROCEDURES.....	15
4-5.	Recording.....	15
4-6.	Punch-in or Insert Recording.....	16
4-7.	Playback of Pre-recorded Tapes.....	16
4-8.	Built-in Autolocators.....	16
4-9.	Repeat Play.....	17
4-10.	Splice Editing.....	17
4-11.	Time Code Track (BR-20T only).....	18
	■ An Introduction to SMPTE Time Code.....	19
SECTION 5	FEATURES AND CONTROLS	
5-1.	REAR PANEL.....	20
5-2.	FRONT PANEL.....	21
SECTION 6	OPTIONAL ACCESSORIES	28
SECTION 7	CARE AND MAINTENANCE	31

SECTION 1 GENERAL DESCRIPTION

1-1. INTRODUCTION

The BR-20 Series are highly flexible and reliable professional stereo audio recorder/reproducers that use 1/4-inch wide tape on 5, 7 and 10-1/2-inch reels, at two selectable speeds : 15 inch/s (38 cm/s) and 7.5 inch/s (19 cm/s). All models are switchable between NAB and IEC equalization.

Basically, the BR-20 is available in three versions. The first is NAB standard, the second is DIN standard, and the third is a time code channel version. The table below shows further differences between them.

Features of the BR-20 include :

- Parallel I/O port for connection to SMPTE/EBU based synchronizers/controllers such as the TASCAM ES-50/ES-51
- Balanced +4 dBm inputs/outputs for professional connections
- Remote transport start and stop via the fader control of a suitably equipped mixer
- Easy access dip-switches change some functions to suit your preference (see "Optional Modifications", page 12)
- 3-point memory, entered either "on the fly" or via SELECT and NUMBER features
- Repeat playback over the desired segment of the tape
- 5-point autolocator : Return-to-zero, Locate to three MEMO points, and Direct Locate
- Search operations followed by Auto Play
- Variety of Edit modes
- Cueing at 2 selectable speeds

- Spool mode for uniform tape pack
- Maximum +/-12% speed variation both in record and playback
- Output/meter source selector switch for each channel
- Memory back-up system (see below, 1-2)

To get the most out of your BR-20, please take the time to read through this manual. Some time spent now will keep you from overlooking some of the features that make the BR-20 a more creative tool. You may discover some new tricks you haven't tried before.

Use of Capital Letters : In general, we use all upper case type to designate a particular switch, control or jack name or label (like PLAY). Some features are described with an upper case first letter (like Output Source Selector switch).

1-2. Memory Back-up Feature

The settings of the most major features of the BR-20 are retained in its back-up memory for about 3 days after the power is turned off, so the BR-20 is ready to continue to operate the moment you turn it on again. Specifically, the following are saved :

1. Tape Run Time Reading
2. TAPE SPEED (HIGH or LOW) and TAPE MODE (FIX or VARI)
3. MEMO 1-3 points
4. Last record or play start point (whichever operation was performed later than the other)
5. Positions of these features :
 - REEL SIZE
 - AUTO PLAY
 - REPEAT
 - Output Source Selector Switches
 - Track REC Enable Switches

BR-20 Version

Version	Destination Country	Gapless Punch-in/Spot Erase	Local Monitor Speaker	Reference Level (nWb/m)
NAB Standard	USA/CANADA	No	Yes	250/320
	Other Countries	Yes	No*	320/514
DIN Standard	Europe/U.K. only	Yes	No*	320/514
Time Code Channel model	USA/CANADA	Yes	No*	250/320
	Other Countries	Yes	No*	320/514

*1) Optionally mountable

SECTION 2 SPECIFICATIONS

2-1. SPECIFICATIONS

MECHANICAL

Tape :	1/4 inch, 1.5 mil, low noise/high output, such as AMPEX #456
Track Format :	
NAB model :	2-track, 2-channel (NAB 0.079 inch, 2.0 mm)
DIN model :	2-track, 2-channel (DIN 0.106 inch, 2.7 mm)
TC model :	2 audio tracks plus IEC standard center track for time code (audio 0.079 inch, 2.0 mm ; time code 0.015 inch, 0.38 mm)
Max. Reel Size :	10.5 inch (NAB hub), 11.1 inch (pancake)
Tape Speed :	Switchable two speeds : 15 ips (38.1 cm/s) and 7.5 ips (19.05 cm/s)
Tape Speed Accuracy :	Within +/-1%
Pitch Control Range :	+/-12%
Wow and Flutter :	
15 ips :	+/-0.06% peak, weighted (DIN 45507)
7.5 ips :	+/-0.09% peak, weighted (DIN 45507)
Fast Wind Time :	120 seconds, maximum (for 2400-foot tape)
Spool Time :	370 seconds, maximum (for 2400-foot tape)
Start Time :	less than 0.3 second
Capstan Motor :	FG DC servo motor, belt drive
Reel Motor :	DC motor x2
Head Configuration :	3 heads for erase, sync/rec, and reproduce ("TC" model only : time code track on erase and sync/rec heads)
External Dimensions (WxHxD) :	19" x 17-1/2" x 7-1/16" (483 mm x 444 mm x 180 mm)
Weight :	61-12/16 lbs. (28 kg)

ELECTRICAL

Input :	Balanced	Unbalanced
Impedance :	10k ohms	50k ohms
Maximum Source Impedance :	600 ohms	3k ohms
Nominal Input Level :	+4 dBm (in CAL)	-10 dBV (in CAL)
Output :	Balanced	Unbalanced
Impedance :	100 ohms	600 ohms
Minimum Load Impedance :	600 ohms	4k ohms
Nominal Load Impedance :	10k ohms	50k ohms
Nominal Output Level :	+4 dBm (in CAL)	-10 dBV (in CAL)

Headphone Output : 150 mW, maximum (8 ohm load)

Bias Frequency : 145 kHz (+/-3 kHz)

Equalization : NAB or IEC, switchable

 In NAB ; 15 ips : 3180 +50 μ s

 7.5 ips : 3180 +50 μ s

 In IEC ; 15 ips : ∞ +35 μ s

 7.5 ips : ∞ +70 μ s

Record Level Calibration :

 USA/CANADA : 250 nWb/m at LOW

 320 nWb/m at HIGH

 Other models : 320 nWb/m at LOW

 514 nWb/m at HIGH

Monitor Speaker : 150 mW, maximum (CH1, MIX, CH2, switchable)

(Optional except for NAB standard USA/Canada model)

Frequency Response for Record/Reproduce (LOW REF LEVEL) :

 15 ips : 35 Hz to 22 kHz (+/-2 dB) at 0 VU

 30 Hz to 22 kHz (+/-2 dB) at 0 VU (Time Code channel model)

 7.5 ips : 30 Hz to 20 kHz (+/-2 dB) at -10 VU

Signal-To-Noise Ratio (Referenced to 3% THD, in CAL)

DIN AUDIO filter/NAB A weighted

Reproduce

15 ips : NAB/TC models : at NAB, 72 dB/79 dB
at IEC, 74 dB/81 dB
DIN model : at NAB, 73 dB/80 dB
at IEC, 75 dB/82 dB

7.5 ips : NAB/TC models : at NAB, 73 dB/80 dB
at IEC, 70 dB/77 dB
DIN model : at NAB, 74 dB/81 dB
at IEC, 71 dB/78 dB

Record/Reproduce

15 ips : NAB/TC models : at NAB, 66 dB/71 dB
at IEC, 67 dB/72 dB
DIN model : at NAB, 67 dB/72 dB
at IEC, 68 dB/73 dB

7.5 ips : NAB/TC models : at NAB, 67 dB/72 dB
at IEC, 64 dB/69 dB
DIN model : at NAB, 68 dB/73 dB
at IEC, 65 dB/70 dB

Distortion : 0.8 % or less, at 1 kHz, 250 or 320 nWb/m
3 % at 1 kHz, 1040 nWb/m, 15 ips

Channel Crosstalk : 60 dB or more (NAB/TC models)
55 dB or more (DIN model)

Erasure : 70 dB or more, at 1 kHz, 790 nWb/m

Power Consumption : 95 Watts

TIME CODE CHANNEL (BR-20T model only)

Input (Balanced)

Impedance : 10k ohms
Maximum Source Impedance : 600 ohms
Nominal Input Level : 2 Vp-p
Minimum Input Level : 0.3 Vp-p
Maximum Input Level : 20 Vp-p

Output (Balanced)

Impedance : 100 ohms
Minimum Load Impedance : 600 ohms
Nominal Load Impedance : 10k ohms
Output Level : 2 Vp-p

Record Level : 707 p-p nWb/m

Crosstalk (to Audio tracks) : 80 dB or more

OPTIONS

- RC-402 Transport Remote
- MA-20 Mic Amplifiers
- SP-20 Local Monitor Speaker (premounted in NAB standard USA/Canada model)

See also the "Optional Modifications" and the "Optional Accessories" section of this manual.

BR-20 External Dimensions

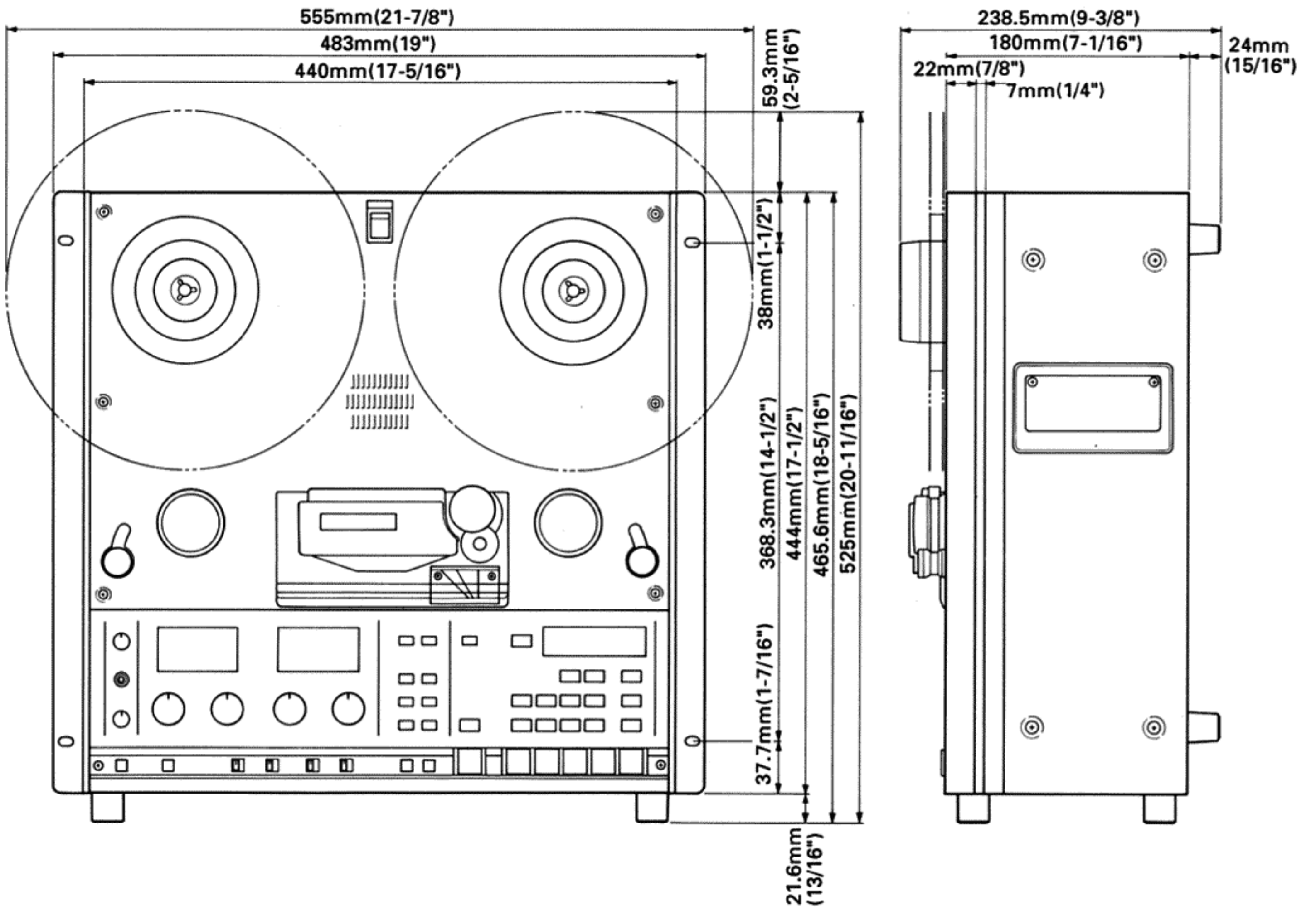

RC-402 (Optional) External Dimensions

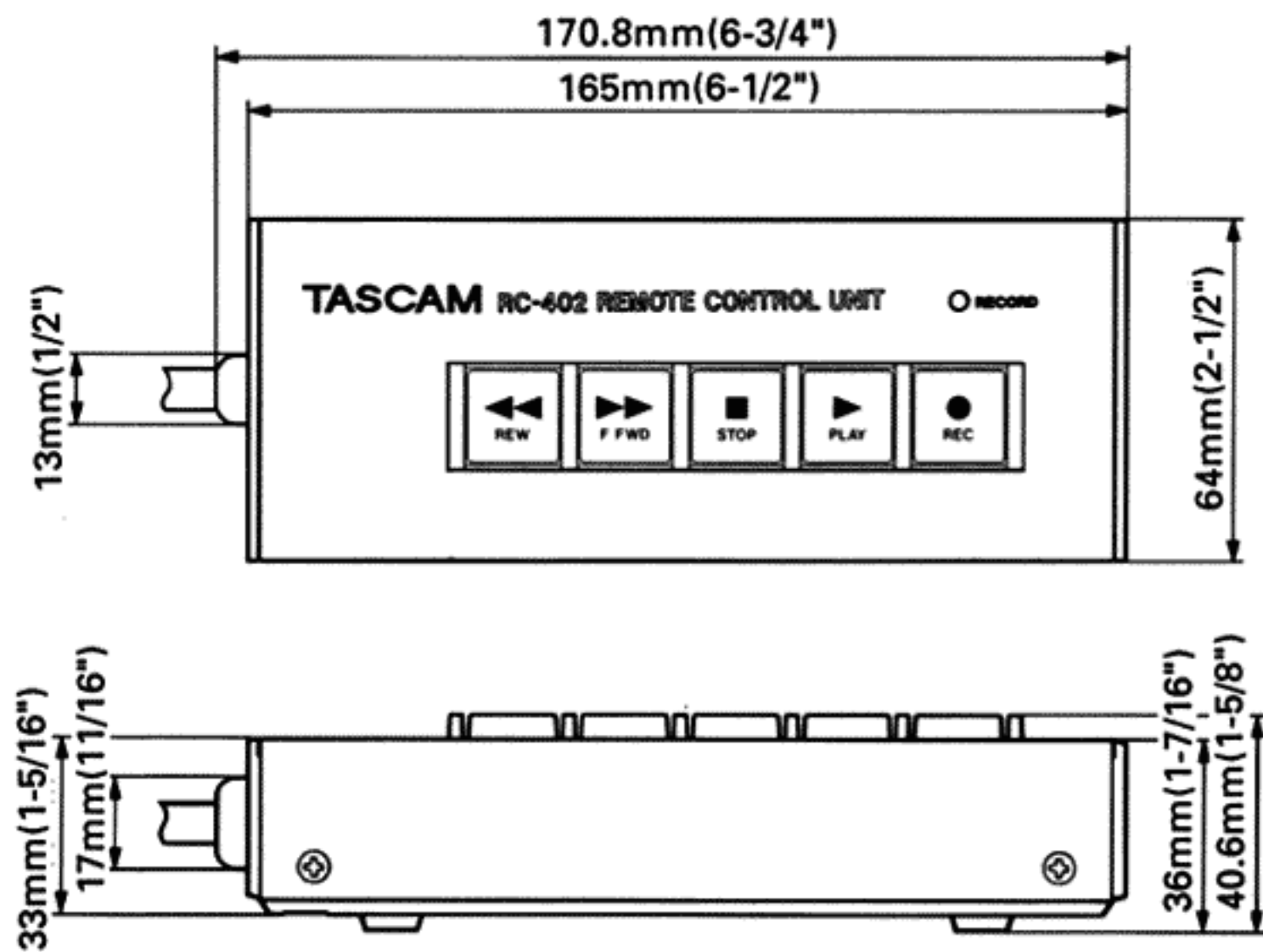

2-2. Control Signal Block Diagram

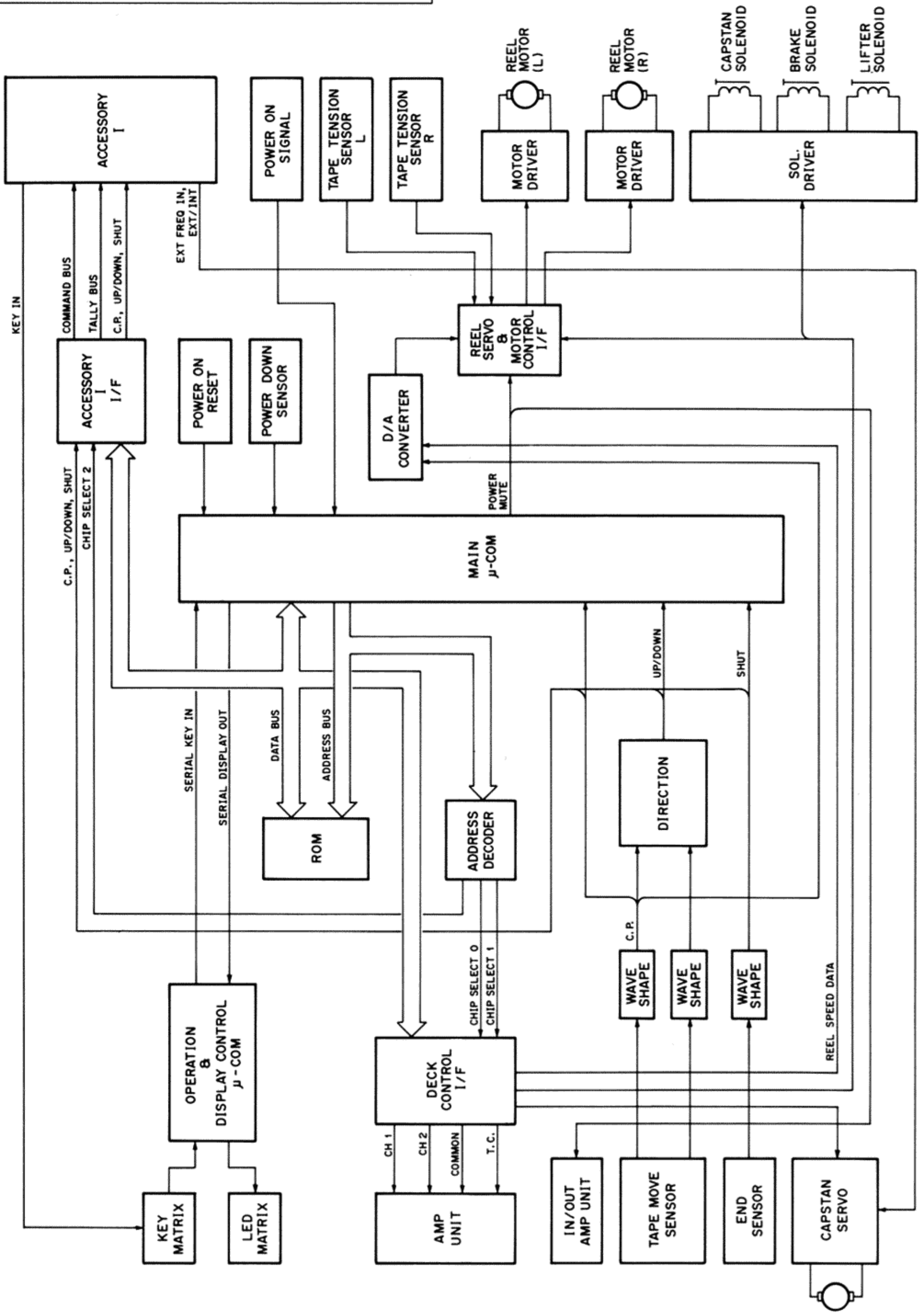

2-3. Audio Signal Block and Level Diagrams

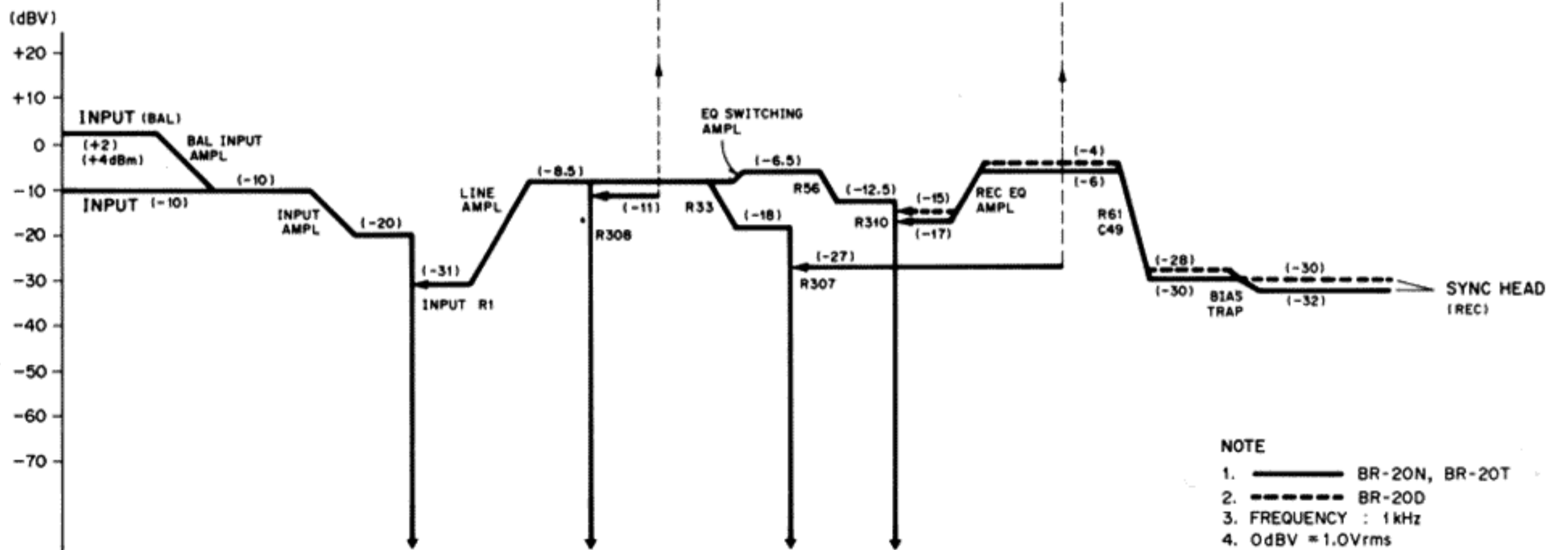
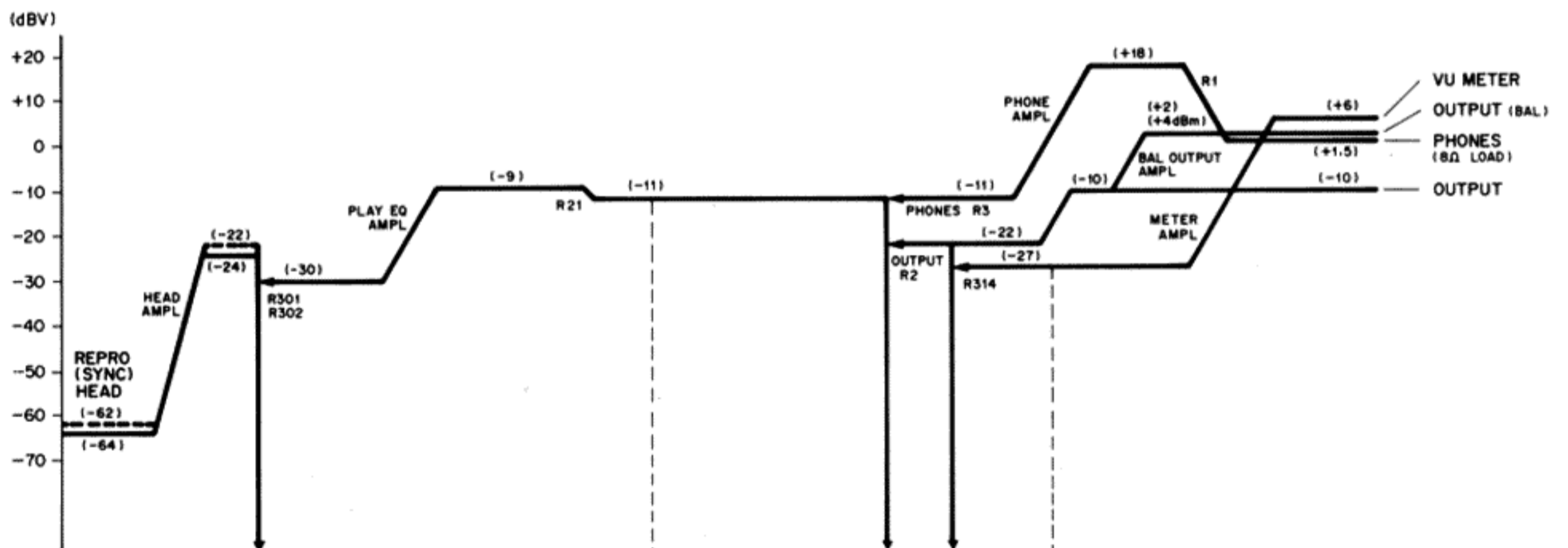
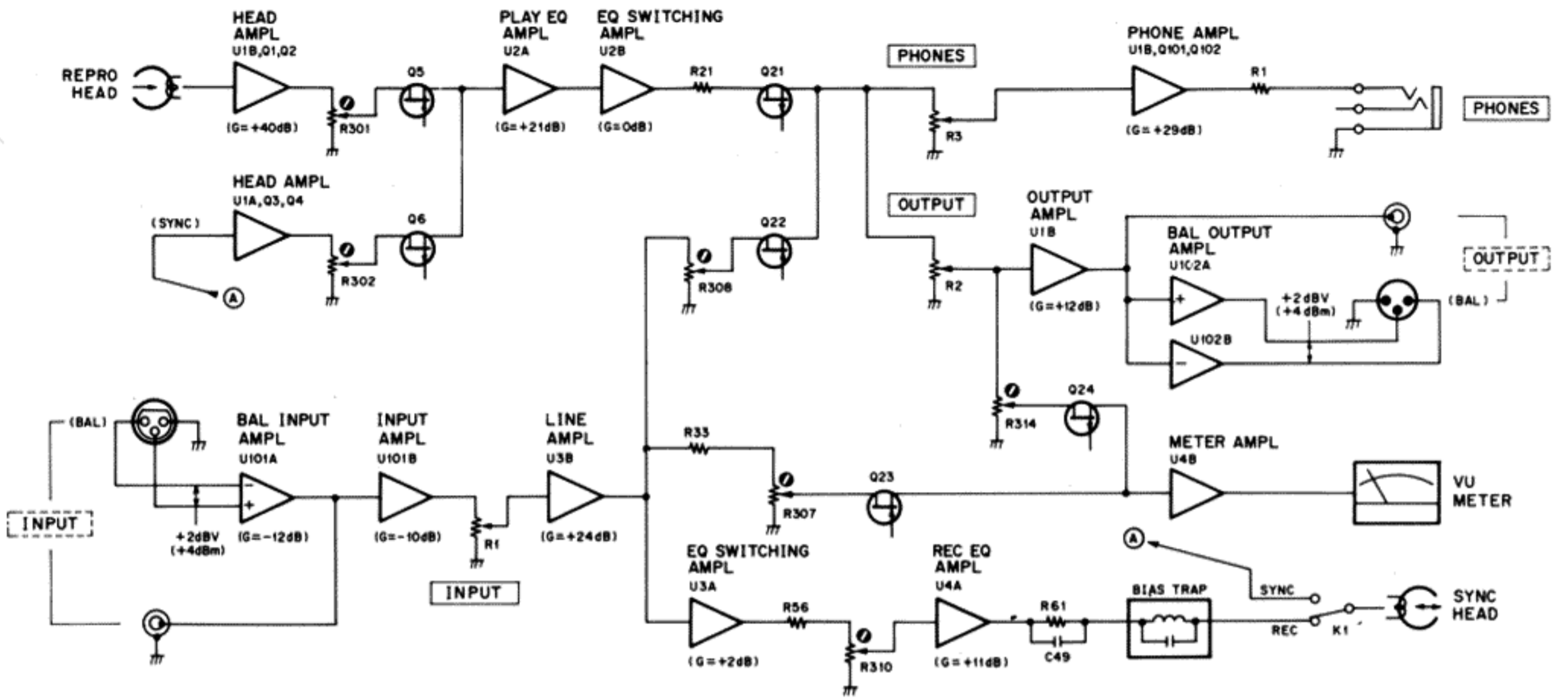

- NOTE
1. ——— BR-20N, BR-20T
 2. - - - - BR-20D
 3. FREQUENCY : 1kHz
 4. 0dBV = 1.0Vrms
 5. 320nW/m

SECTION 3 INSTALLATION

3-1. UNPACKING AND INSPECTION

During unpacking, be careful not to damage the BR-20. Save the carton and packing material. You may need them to transport your BR-20 sometime in the future.

In addition to the BR-20 recorder/reproducer, the package should contain the following :

Reel adapter (TZ-614) x2
10.5 inch reel x1
Feet mount screw (pan head) x4
Rack mount screw (oval countersunk head),
w/washer and spacer x8
Operation/maintenance manual x1
Warranty card x1

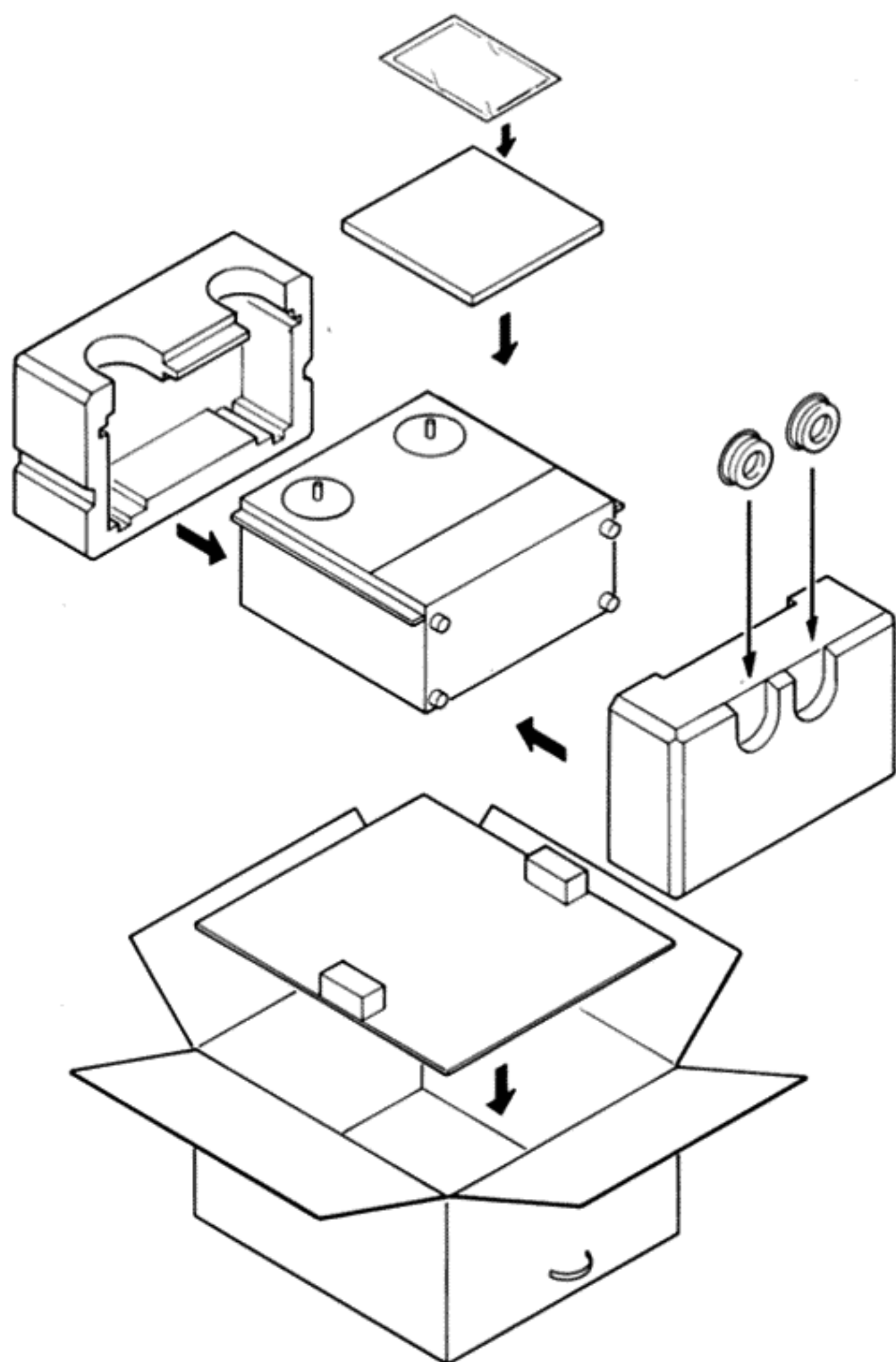

After unpacking, check the units for any evidence of damage due to rough handling during transport. Contact your dealer if you have any questions.

● HOW TO REMOVE THE HEAD ACCESS COVER

Gently press the left side of the cover to the right and lift the left side up slightly. Then pull and lift to the left to release fully. When replacing the cover, first insert the tab into the slot on the right side of the head assembly, then gently press the left side in to lock it into position. **DON'T FORCE IT.** Carefully handle both in removing and replacing.

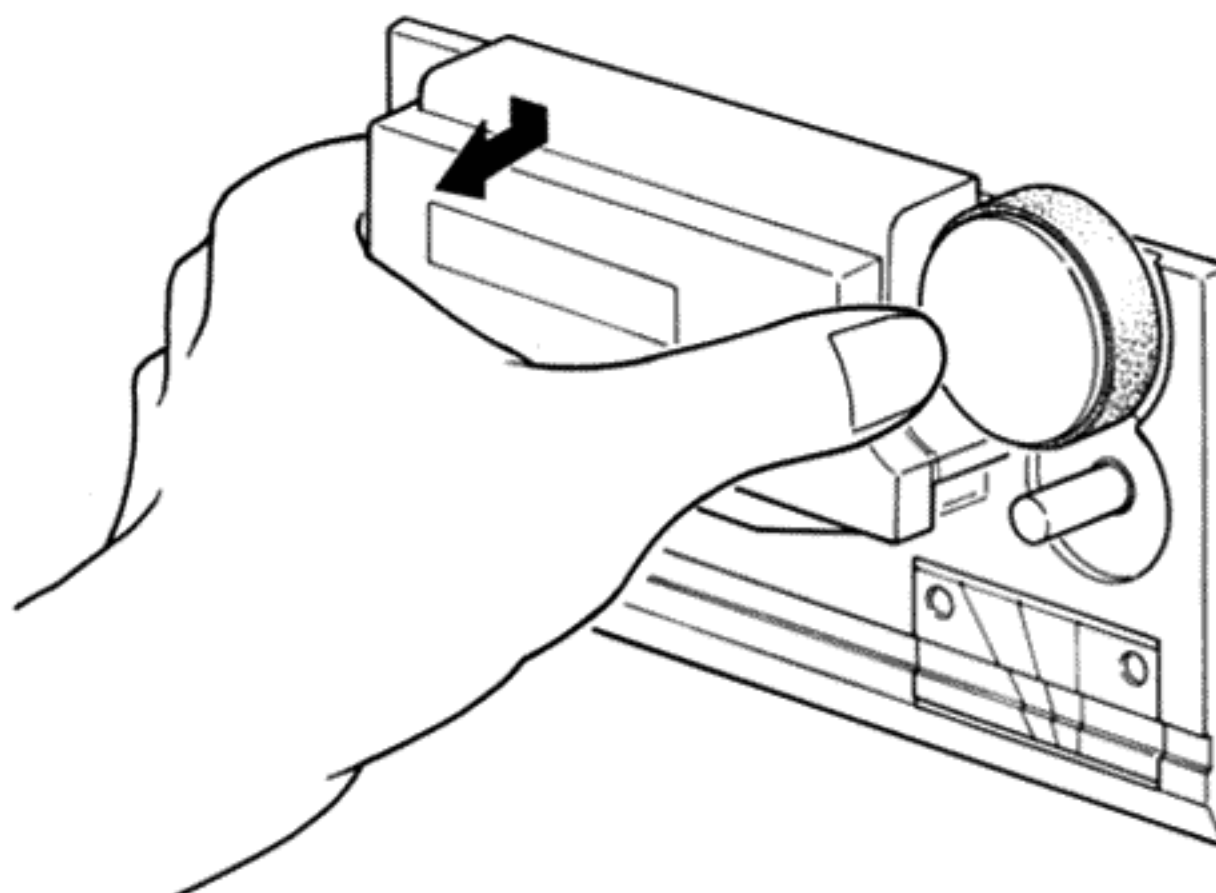

NOTE FOR U.K. CUSTOMERS

Due to the variety of plugs being used in the U.K., this unit is sold without an AC plug. Please request your dealer to install the correct plug to match the mains power outlet where your unit will be used as per these instructions.

IMPORTANT

The wires in this mains lead are coloured in accordance with the following code:

BLUE: NEUTRAL
BROWN: LIVE

As the colours of the wires in the mains lead of this apparatus may not correspond with the coloured markings identifying the terminals in your plug, proceed as follows;

The wire which is coloured **BLUE** must be connected to the terminal which is marked with the letter **N** or coloured **BLACK**. The wire which is coloured **BROWN** must be connected to the terminal which is marked with the letter **L** or coloured **RED**.

3-2. OPTIONAL MODIFICATIONS

There are two DIP-switches on the Control PC Board inside the BR-20. Their default settings and functions are as follows :

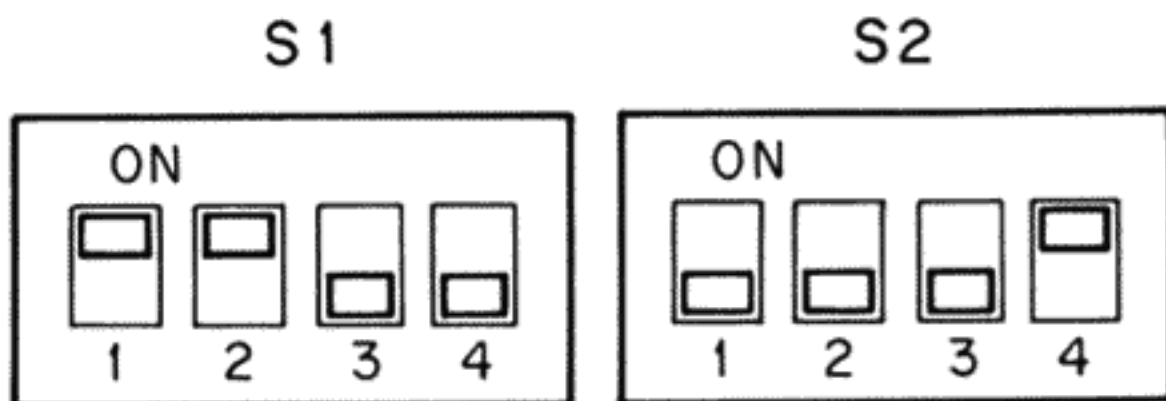

Caution: Leave switches #3 and 4 of S2 alone: #3 down, #4 up.

S1-1 : ON (Memory Back-up feature is active)
S1-2 : ON (Fader Stop function is available)

- Fader Start function can also be switched on/off. As for the procedure, see the "Features and Controls" section of this manual, item 43.

The next S1-3 switch has no effect on the NAB standard U.S.A/Canada model.

S1-3 : OFF (Gapless punch-in and spot erase are active)

Note : S1-3 is a "defeat" switch and "OFF" means the function is NOT defeated.

S1-4 : OFF (Tape speed is switchable between 7.5 inch/s (19 cm/s) and 15 inch/s (38 cm/s))

- ON position is for 3-3/4 and 7-1/2 inch/s (9.5 and 19 cm/s) tape speeds. This entails installation of some internal parts. Consult TASCAM or your nearest TASCAM dealer.

S2-1 : OFF (On-the-fly tape point capture and its storage into memory are done at once by hitting a MEMO key alone.)

- With this switch set to ON, MEMO only captures the current tape point, and, when NUMBER is subsequently pressed, that point is actually memorized.

S2-2 : OFF (Monitor source : INPUT, SYNC, and REPRO, can be selected for the separate channels)

- With this switch set to ON, both channels' monitor sources are selected at once by either channel's selector switch.

Information on how to get access to the DIP switches is found in the "Maintenance" section of this manual.

The following options and modifications are also available :

1. Installation of mic amplifiers (MA-20)

Additional features of the optional MA-20 are described in the "Features and Controls" section of this manual.

2. Installation of a local monitor speaker (SP-20)

The SP-20 is premounted in the NAB standard USA/Canada models.

3. Changing the basic transport control key layout to suit your preference sequence

The above options and modifications can not be installed or performed by the end user. Consult TASCAM or your nearest TASCAM dealer.

VOLTAGE CONVERSION (General Export Models Only)

NOTE : Voltage conversion is not possible on models sold in the U.S.A., Canada, U.K., Australia or Europe.

For general export models only, if the input voltage specified on the machine, power cord tag, or packing carton differs from the line voltage at the installation site, please request your dealer to change the voltage setting of the machine. The procedure entails the opening of the machine.

3-3. INSTALLATION SITE

The BR-20 may be used in most areas, but to maintain top performance and prolong operating life, observe the following environmental limitations :

- 1) Nominal temperature should be 5 to 35 degrees Centigrade (41 to 95 degrees Fahrenheit).
- 2) Relative humidity should be 30 to 90% (non-condensing).
- 3) Strong magnetic fields should not exist nearby.

3-4. Rack Mounting the BR-20

The BR-20 may be mounted to a standard EIA 19" rack, such as the TASCAM CS-608 or CS-607B. Before mounting, make sure the rack you are mounting the BR-20 to is not warped or bent. Screwing to a badly warped surface may cause misalignment of the transport.

- BR-20 in horizontal position

When the BR-20 is operated on its back in a horizontal position, remove the "A" and "B" feet (each four), attach the "A" feet to the back, then attach the "B" feet to the "A" feet, as shown. This allows sufficient space at the back of the machine for the protruding XLR type connectors.

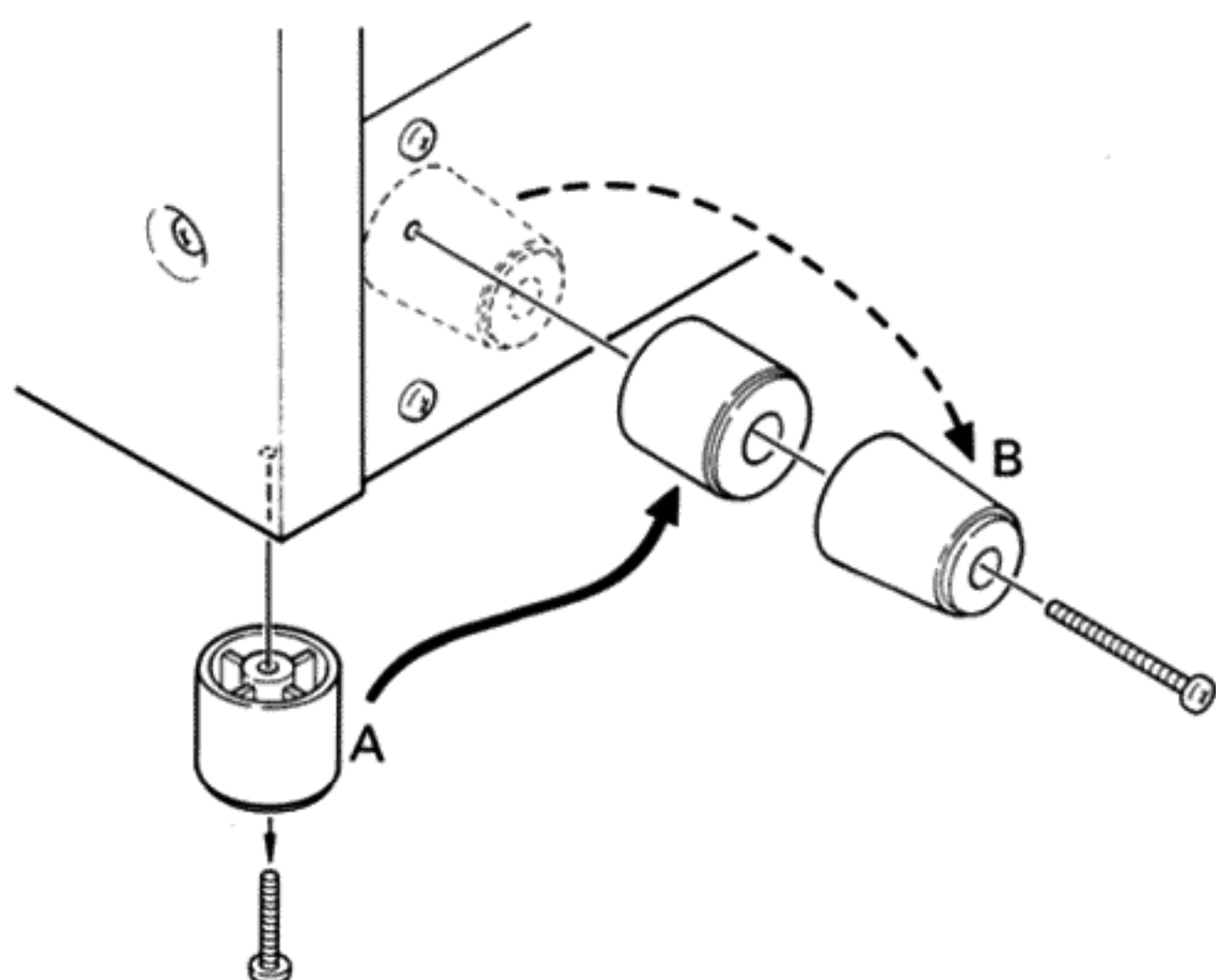

3-5. INITIAL CONNECTIONS

CAUTION : To prevent problems, before attempting any cable connection check to make sure all units involved in your system are turned off.

When connecting the BR-20 to your system, use shielded cables that are as short as your situation will allow. We recommend low-capacitance cables with quality connectors, such as the TASCAM Pro Series. Cheaper cable has less shielding and may introduce radio frequency interference, hum and noise into your system.

A. Input/Output Connections

The BR-20's line inputs and outputs are handled both by XLR type connectors (+4 dBm standard) and RCA jacks (-10 dBV standard) located on the rear connector panel of the machine.

The stereo buss output of your mixer may be connected to the CH1 and CH2 INPUTs of the BR-20. The OUTPUTs of the machine may be sent

back to the monitor section of the mixer, or directly to your amplifier/monitor system, depending on the application.

- When the optional MA-20 Mic Input Amplifiers are mounted...

Connect mic signals to the MIC inputs. When the front panel's MIC/LINE selector switch is set for MIC inputs, the ATT switch located beside each MIC input connector can be set for 20 dB attenuation of MIC signals to prevent to distort the mic amplifiers.

B. "ACCESSORY 1" Connection

On the BR-20's rear panel is located an ACCESSORY 1 connector that is a parallel port, meaning transport controls are each brought to a separate pin of the connector for external connection to the TASCAM ES-50 or other SMPTE/EBU synchronizers.

Alternatively, the ACCESSORY 1 connector is used for connection to the optional transport remote control unit, or to fader switches so the transport start and stop are controlled from the fader of a mixer. Pin 25 of the connector is assigned for the fader start/stop (see chart on the right).

- Synchronizer Interface

Connection between the ES-50 Synchronizer/ES-51 Edit Controller and the BR-20 is a plug-and-go proposition. Pre-wired interface cables needed are available from TASCAM.

The BR-20 provides signals to the synchronizer which indicate its speed, the direction of the tape travel, and a reference power supply. Also, tally signals indicating the BR-20's mode (PLAY, F.FWD, REW, STOP) are given to the synchronizer so it knows the current transport status. Inputs on the same ACCESSORY 1 connector are provided for status commands from the synchronizer (PLAY, F.FWD, REW, STOP, REC, LIFTER CONT). Also, there is an input for a capstan drive reference frequency signal from the synchronizer so that the actual record/play speed can be varied to maintain synchronization.

NOTE : Take the appropriate measure to prevent a ground loop from occurring through the ACCESSORY 1 connector. If you have questions, consult a person familiar with studio grounding techniques.

The BR-20 will operate satisfactorily with a variety of other manufacturers' synchronizer/controllers. The manual for these products should provide you with enough interface information for use with the TASCAM tape machines. Or else, consult the synchronizer manufacturer for further details on interface.

ACCESSORY 1 Pin Assignment Chart

Pin #	IN(put) – OUT(put) signals	Function
1	PLAY IN	Inputs PLAY signal at L level.
2	FF IN	Inputs FF signal at L level.
3	REW IN	Inputs REW signal at L level.
4	open terminal	
5	STOP IN	Inputs STOP signal at L level.
6	REC IN	Inputs REC signal at L level.
7	LIFTER CONT IN	Inputs LIFTER shift cancellation signal at L level.
8	open terminal	
9	UP/DOWN OUT	Outputs tape running control signal at H or L level.
10	CP OUT	Outputs open-collector signal (12 Hz pulse at 15 ips.)
11	PLAY TALLY OUT	Outputs open-collector signal (Low level during PLAY mode.)
12	FF TALLY OUT	Outputs open-collector signal (Low level during REW mode.)
13	REW TALLY OUT	Outputs open-collector signal (Low level during REW mode.)
14	STOP TALLY OUT	Outputs open-collector signal (Low level during STOP mode.)
15	REC TALLY OUT	Outputs open-collector signal (Low level during record mode.)
16	SHUT-OFF TALLY OUT	Outputs open-collector signal (Low level during tape stop)
17	open terminal	
18	open terminal	
19	REW COMMAND OUT	Outputs open-collector signal (Low level when REW is pressed)
20	FF COMMAND OUT	Outputs open-collector signal (Low level when F. FWD is pressed)
21	PLAY COMMAND OUT	Outputs open-collector signal (Low level when PLAY is pressed)

Pin #	IN(put) – OUT(put) signals	Function
22	STOP COMMAND OUT	Outputs open-collector signal (Low level when STOP is pressed)
23	REC COMMAND OUT	Outputs open-collector signal (Low level when REC is pressed)
24	open terminal	
25	F. START IN	Transport start from fader switches, active at Low level. (See also diagram below.)
26		
27		
28	open terminal	
29		
30		
31	EXT FREQ IN (HOT)	Inputs speed control signal at input signal of 3.0 V or more and of 9.6 kHz, -40 to +30 % (HOT side)
32	EXT FREQ IN (COLD)	Inputs speed control signal (COLD side)
33	INT/EXT IN	Inputs internal/external speed control select signal. Internal: HIGH level External: LOW level
34	open terminal	
35	+15 V supply voltage OUT	Maximum: 50 mA
36	Main unit GND	
37	+5 V supply voltage OUT	Maximum: 50 mA

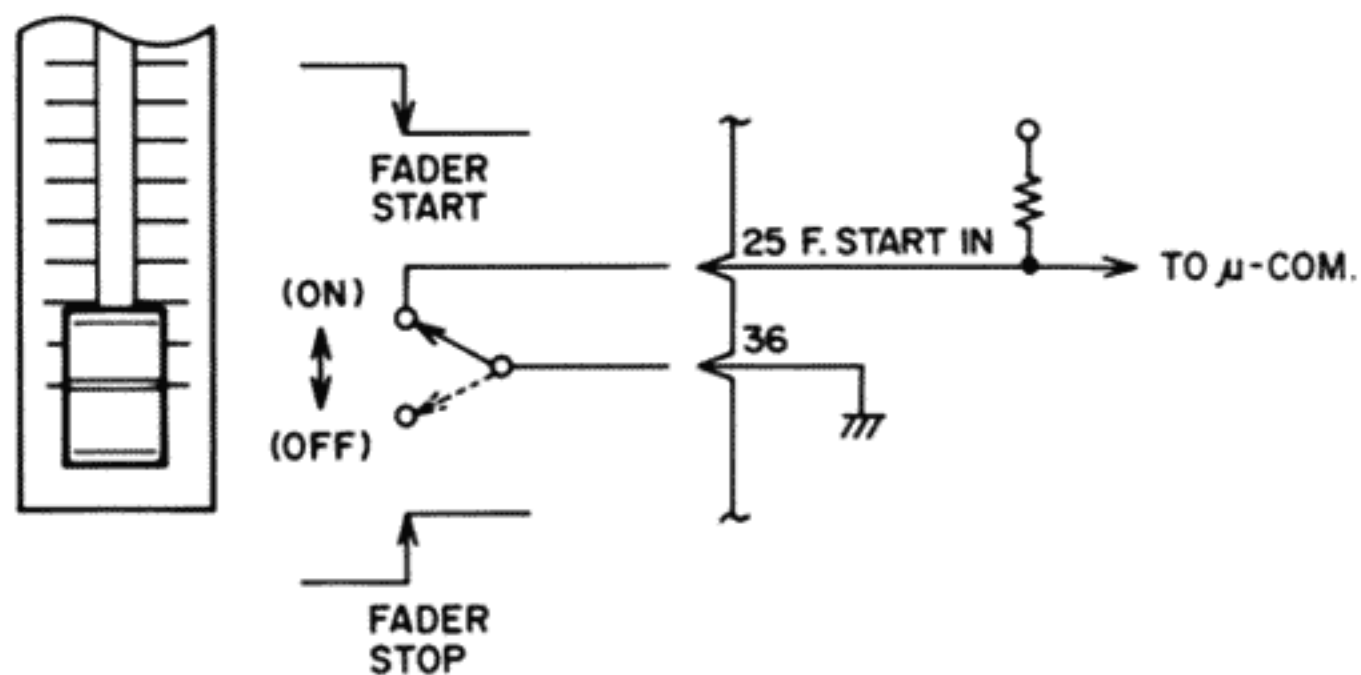

The BR-20 responds to the fader start command only when it is in STOP and responds to the fader stop command only when it is in PLAY : the transport toggles STOP and PLAY.

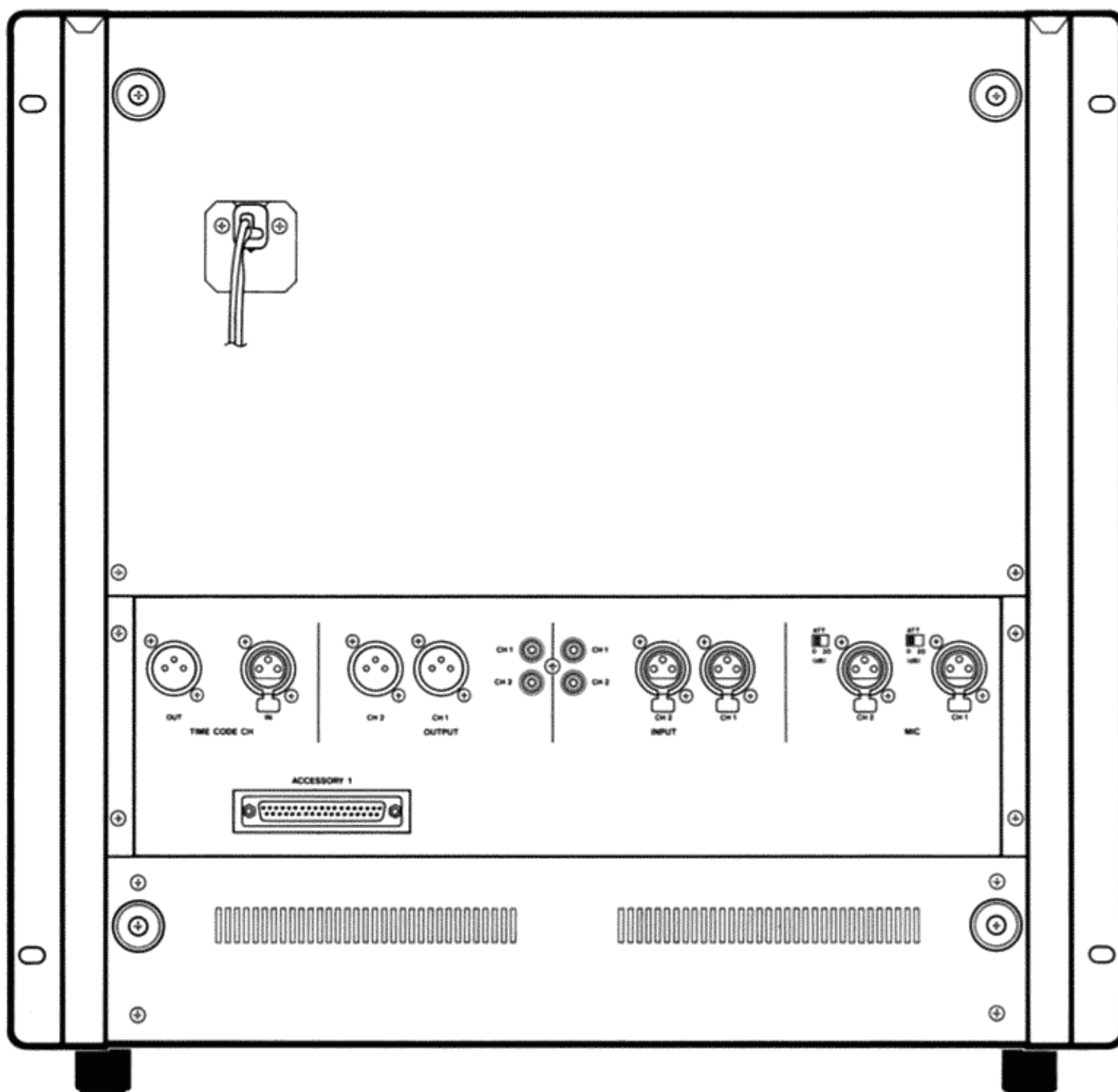
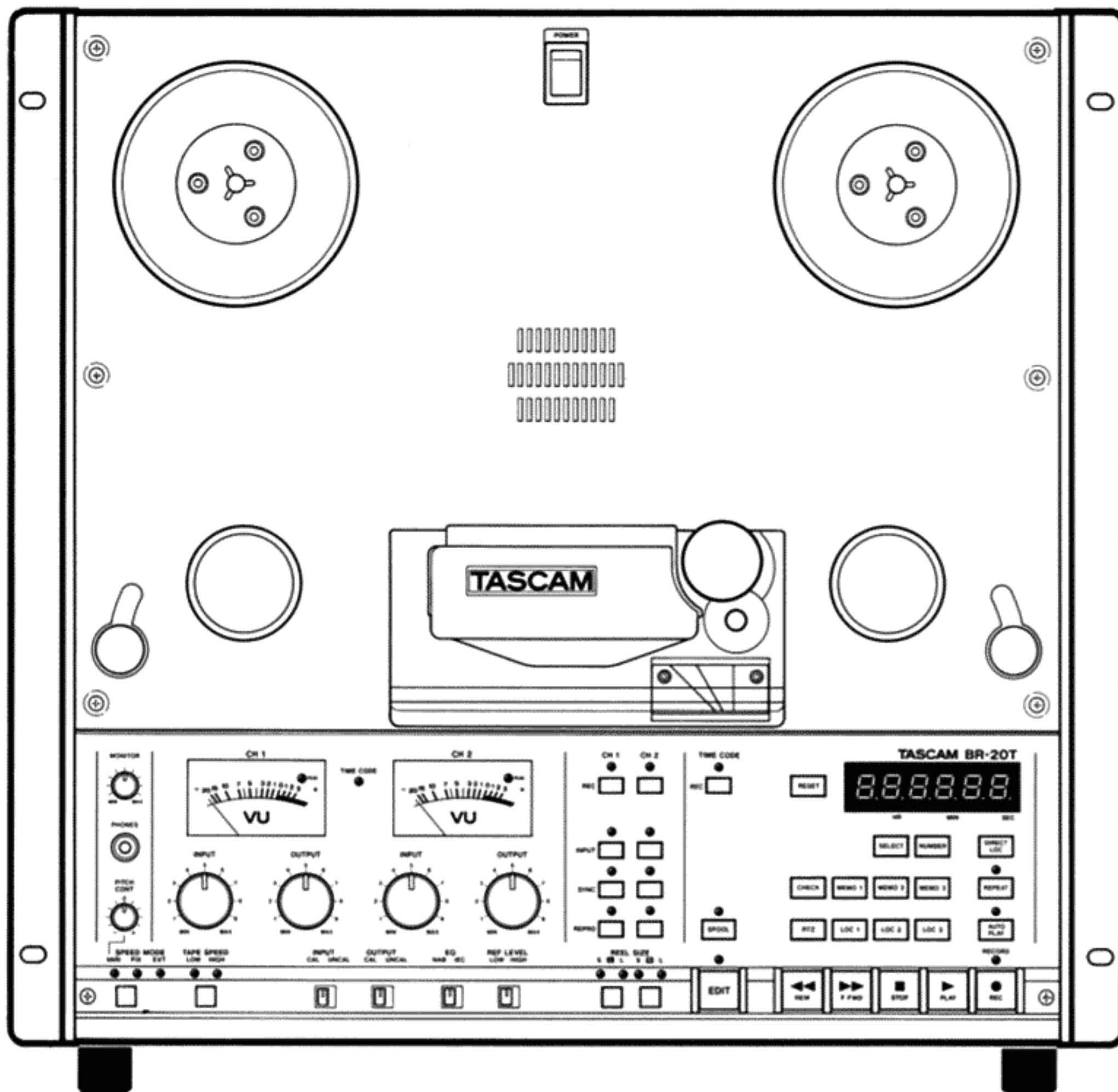

SECTION 4 OPERATION

4-1. PRE-OPERATING PROCEDURES

4-2. Reel Installation

The BR-20 accepts 5 or 7 inch (12 or 17 cm) reels with small hubs (EIA standard) and 10.5 inch (26 cm) reels with large hubs (NAB standard). Thanks to the separate REEL SIZE selector switches for both the supply and takeup sides, it is not absolutely necessary to mount the same size of reels on both sides.

• Small Hub Reels :

When using 5 or 7 inch reels with small hubs, proceed as follows :

1. Line up the three slots in the center hole of the reel with the three holding keys in the inner section of the reel-table spindle and push the reel against the reel table.
2. Pulling the spindle up, rotate it in either direction about 60 degrees, then release your hand. The reel will lock in place.

Reverse the procedure to remove the reel.

• Large Hub Reels :

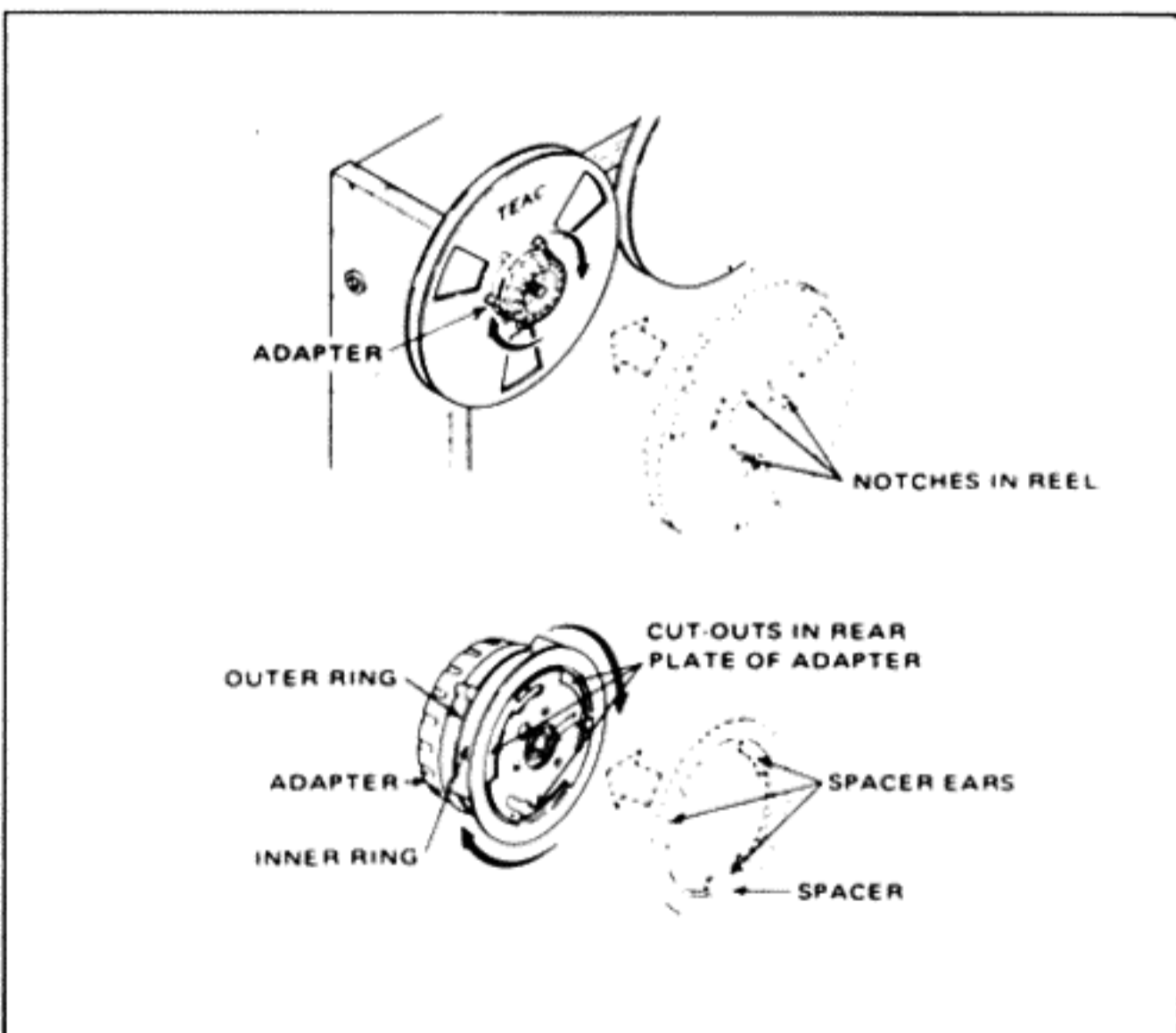

A metal spacer is mounted on the back of the provided reel adapters (TZ-614), and must be in place as shown above when installing 10.5 inch metal reels. When installing plastic reels, remove the spacer by turning it counterclockwise.

To install 10.5 inch reels with large hubs, proceed as follows :

1. Turn the reel adaptor knob fully counterclockwise.
2. Line up one of the three slots in the reel hub with the locating pin on the reel table.
3. Push the reel against the reel table until it is seated.
4. Turn the reel adaptor fully clockwise.
5. Before running tape, make sure that the reels are firmly secured to the reel adapters and the adapters are firmly secured to the reel spindles.

4-3. Tape Threading

1. If you didn't yet, place a full reel of tape on the supply (left) reel table and an empty reel on the takeup (right) reel table. Secure both reels as explained above, 4-2.
2. Refer to illustration below and thread the tape exactly as shown.
3. Rotate the takeup reel until there is no slack in the tape.

Before running tape, check to see both reels are firmly locked in place.

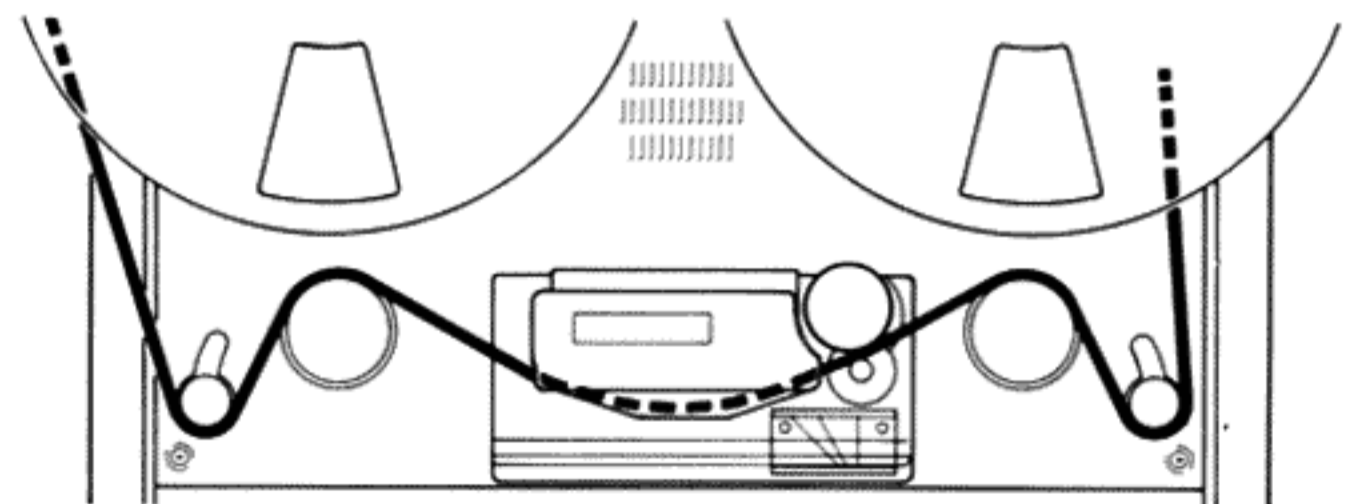

4-4. OPERATING PROCEDURES

CAUTION

Keep your fingers away from a running tape edge. Don't operate the POWER switch when tape is moving; first press STOP to stop the tape.

4-5. Recording

1. Check to see all the connections have been made correctly.
 2. Turn the power on.
 3. Load a blank tape as per instructions under paragraph 4-3.
 4. Set the REEL SIZE selector switches both to SMALL or LARGE, or one to SMALL and the other to LARGE, depending on the reels in use.
 5. Set the TAPE SPEED switch to HIGH for the best quality recording.
 6. Set the SPEED MODE switch to FIX.
 7. Check to see the EDIT LED is off. If not, turn it off by pressing the key.
 8. Set the EQualization switch to match NAB or IEC equalization curve, as necessary.
 - On MIC input model, the EQ selection is made by a DIP switch on the MIC AMP PC Board. The default setting is NAB or IEC as ordered.
 9. Set the REF LEVEL switch to appropriate position for kind of tapes being used.
 - On MIC input model, the REF LEVEL is selected by a DIP switch on the MIC AMP PC Board. The default setting depends on the request.
 10. (MIC input model only) — Set the CH 1 and CH 2 MIC/LINE selector switches to match the input sources.
 11. Set the CH 1/CH 2 INPUT level controls to the nominal "7" position.
 12. Set the CH 1/CH 2 OUTPUT level controls to the nominal "7" position.
 13. Place the INPUT CAL/UNCAL switch in the right/UNCAL position.
 14. Press the RESET key, so you can use RTZ (Return-To-Zero) to get back to this point.
- #### Setting the Record Level
15. Set the Output Source Selector switch of both channels to INPUT so you can monitor input signal by the VU meters before starting tape.
 16. To hear input signal, properly set the monitor section of your mixer; or, plug in headphones to the PHONES jack.
 - NAB standard U.S.A/Canada model — Keep the PHONES jack empty if you want to use the internal local monitor speaker.
 17. Play your multitrack, and watch the meter on the mixer and the VU meters on the BR-20. At the loudest point, both meters should peak at the reference level of "0". If not, adjust the stereo master fader on the mixer and the INPUT level controls on the BR-20. (Check to make sure the INPUT CAL/UNCAL switch is set to UNCAL position.)
 18. (On MIC input model only) — Speak into the mic, at levels that are expected during the performance and adjust the INPUT level controls for "0 VU" reading.
 19. When the record level has been properly set, rewind the multitrack.
 20. Press the SYNC switch of both channels, so the meters show signals read off the tape until recording starts. Once recording started, the meters will automatically switch to show input signals.
 21. Press both CH 1/CH 2 REC Enable switches for two-channel recording. A red LED will start blinking above the switches, indicating "Record Ready" mode.
 22. To initiate recording, press both the master REC and the PLAY key. The tracks' REC LEDs will turn on solid.
 23. When recording is complete, press STOP.
 24. Press the REC Enable switches again. Their blinking LEDs will go out showing the tracks are now in "Safe".
- #### Review
25. Press the RTZ key. The tape will rewind, automatically stopping at counter zero point. (You could also press DIRECT LOC instead of RTZ.)
 - Optional : You can press AUTO PLAY before or after RTZ. Then, the tape will automatically start playing when the counter zero point is reached.
 26. If AUTO PLAY is not active and the tape stops, press PLAY.

4-6. Punch-in or Insert Recording

GAPLESS PUNCH-IN/OUT

- NAB standard U.S.A./Canada models do not have the gapless punch-in function.

Although the advanced circuitry of the BR-20 allows gapless punch-in on the tape, there is still the distance between the erase and record heads to be compensated for. Depending on tape speed, the time from a punch in to the actual in/out is 1/15th or 1/8th of a second. A few practice runs will get you accustomed to the timing of punching in.

The BR-20 offers two ways to initiate the punch-in :

Method 1. Punching with the Master REC Key

1. Press the REC Enable switch of the track you intend to punch in. Its LED will start blinking.
2. Press PLAY. If the track's Output Source Selector switch is at SYNC, you will hear the tape. Set the switch to INPUT to hear the input signal.

Adjust the input and output (monitor) levels for the desired balance.

- When the level balance is achieved, be sure to set the Output Source Selector switch to SYNC.
3. When the tape reaches the desired punch-in point, press the master REC key ("master" opposed to "track") to start recording. The monitor will switch from tape to input on that track (provided that the Output Source Selector switch is at SYNC). Both the master and track REC LEDs should now be on solid.
 4. Punch out by pressing STOP or PLAY.

Method 2. Punching with the Track REC Switch

1. After the recording and monitoring levels are set, make sure that both tracks are SAFE (no track LED blinking).
2. Press the master REC key together with PLAY to start playing the tape. Both the master and track REC LEDs will blink, showing the machine is in Record Ready mode.
3. Press the punch-in track's REC switch when the tape reaches the punch-in point. Both the master and track REC LEDs will light up steadily, showing recording is taking place.
4. To punch out, press the track REC switch again (you could also press STOP or PLAY).

4-7. Playback of Pre-recorded Tapes

1. Load a pre-recorded tape as per instructions under paragraph 4-3.
2. Set the REEL SIZE selector switches to match the size of reel in use.
3. Set the TAPE SPEED switch to match the speed at which the tape was originally recorded.
4. Check to see the EDIT LED is off.
5. Set the EQ and the REF LEVEL switch to the positions used for recording the tape.
6. Press PLAY to begin playback.
7. To stop the tape, press STOP

4-8. Built-in Autolocators

The BR-20 has three tape location memories : MEMO 1-3.

1) "On the fly" entry

Simply hit one of the three MEMO keys at the desired moment. The counter display at that moment is retained in the machine's memory system.

- You can modify the MEMO circuitry so the MEMO point is stored into memory only when the NUMBER key is pressed after MEMO. See the "Optional Modifications" section of this manual.

2) Using SELECT and NUMBER

Proceed as follows :

1. Press the SELECT key. The digital counter will switch to MEMO point setting/storage mode. The display will look like this :



2. Press the NUMBER key until the desired numeral appears.



- Press the SELECT key again. The blinking "0" will reappear but in the SEC 10th digit window this time. Press NUMBER until the desired numeral appears.

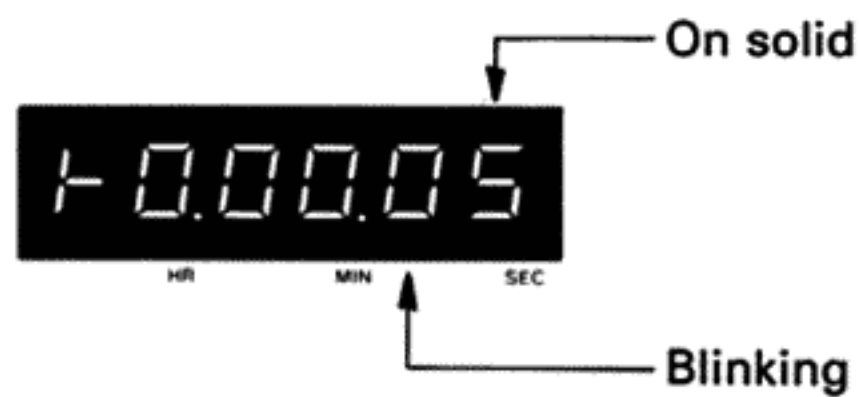

In a similar way, enter the desired whole number.

- When the desired location time is fully entered, press one of the three MEMO keys.

The counter will switch back to its normal time counter mode.

- To abort the MEMO point setting procedure before pressing a MEMO key (that is, before performing step 4 above) and quit SELECT mode, press any of the transport keys. Note that pressing CHECK is also the same effect.
- To locate the tape to a MEMO point, press the same numbered LOC key. If AUTO PLAY is active, the tape will automatically start playing after search operation.

3) Direct Locate

If you press the DIRECT LOC key after completion of step 3 above (that is, before pressing MEMO), the tape will be located to the point you've entered via SELECT/NUMBER, directly, without being loaded into memory.

4-9. Repeat Play

- Use two of the three MEMOs to establish the beginning and the end point of loop (see above, 4-8).
- Press REPEAT (in whatever the current transport mode is). Its LED will start blinking.
- Press the desired two MEMO keys.

The tape will be located to the lower MEMO location while the counter display will show the beginning and the end point of your loop. The REPEAT LED that was blinking will go on solid if the current tape location is within the two MEMO points (the LED will continuously be blinking if the current tape location is out of the two MEMO points). As soon as that location is reached, the tape will automatically start playing to the higher MEMO location, rewind to the lower MEMO location and start over.

- To verify which MEMOs define the current loop, press CHECK (when the REPEAT LED is blinking or stay on solid). A broken line will appear in the counter display. Then, hold REPEAT. Two MEMO numbers (not MEMO contents) will be displayed. To go back to the normal counter mode, press CHECK again.

To stop REPEAT sequence :

- To definitely leave REPEAT mode, press REPEAT again. Its LED will turn off.
- To interrupt the sequence temporarily, press any transport keys (except for PLAY). The function pressed will be activated, and if you get past the beginning or end of your loop, the REPEAT LED will start blinking. To resume the REPEAT sequence, press the appropriate LOC key to locate the tape to the lower MEMO point, or, if you are now within the loop or behind the lower MEMO point, press PLAY.
- During REPEAT (whether a sequence is currently playing or not), the remaining third MEMO register is available for storing a new tape location, but the two MEMO registers in use for REPEAT are not.
- You can directly initiate record from REPEAT mode. But, the REPEAT function is continuously active (the REPEAT LED will continue to blink or stay on solid) until you press REPEAT.

4-10. Splice Editing

Preliminary Notes :

- When splicing tape, never use ordinary adhesive or pressure sensitive tape. Use only special tapes made for splicing (editing) recording tape. Splicing tape has a small amount of low-tack adhesive which is adequate to grip the backing of the recording tape, yet which will not "ooze" out beyond the splice after being wound under tension and shuttled over the heads. Conventional tape almost always "leaks" adhesive onto the heads and onto adjacent windings of tape on the reel.
- Always use non-magnetic tools, including razor blades, when splicing tape. Magnetized tools will cause a "click" upon playback.

The following is just one of the tape editing procedures that can be accomplished on the BR-20. For more possibilities that the EDIT feature provides, see the "Features and Controls" section of this manual, item #21.

1. To locate the section to be edited, press EDIT (while in STOP mode), then hold F.FWD or REW. The tape lifters will retract so the tape contacts the heads, allowing you to monitor the tape as it runs at F.FWD or RWD speed.
2. When the approximate point is cued out, release F.FWD or REW. The tape will stop.
3. Rotate the reels by hand in either direction until you hear the exact location on the tape.
4. When the exact point is cued out, open the head access cover and use a grease pencil ("china marker") to mark the cut point opposite the rec/sync head if the Output Source Selector switch is at SYNC, or the repro head if set to REPRO).
5. Pull the tape forward and lay it on the splicing block (oxide down) and cut the tape at the mark using a non-magnetic single-edged industrial razor blade.
6. If a substantial length of tape is to be removed, rethread the tape from the supply reel past the heads, capstan, and pinch roller... and let the end hang off the right side of the transport.
7. Holding down EDIT, press PLAY. The tape will unthread itself ("dumping") from the supply reel as you listen to it play.
8. When you cue out the last of the unwanted section of tape, press STOP.
9. Press EDIT again, and manually move the tape so the splice point is opposite the head being used for cueing, mark that point, and cut the tape at the mark.
10. Butt the two cut ends from the supply and takeup reels, apply a small piece of splicing tape, and trim the excess along both edges of the recording tape.

4-11. Time Code Track (BR-20T only)

The BR-20T is provided with the capability of recording and reading SMPTE/EBU time code (29.97 fps, 30 fps, 24 fps, and 25 fps) on an IEC standard 0.3 mm wide track centered on the rec/sync head. The same track spacing is also used on the erase head.

FSK sync tones can also correctly be recorded on the time code track. But, you can't use the track for recording normal audio signals.

The sequence in which time code and audio program are recorded will depend on the particular application, and may be as follows :

1. First record time code, then record audio program with the BR-20T synchronized to other time code based equipment, or inversely, first record audio then time code.
2. Record time code and audio simultaneously.

Preliminary Notes :

- Be sure the audio tracks are in "safe" with their LEDs off unless you intend to record them together with the time code track simultaneously.
- To avoid crosstalk between the center track and the audio tracks, be sure to record the audio material at the correct level.

Striping Time Code

A complete explanation of procedures will be found in the manual for your synchronizer but here are a few notes about recording and playing back SMPTE/EBU that you must know.

1. Take the time code generator output of your synchronizer and plug it into the TIME CODE CH "INPUT" of the BR-20T.

The time code fed into the BR-20T is looped out from the TIME CODE CH OUTPUT, allowing you to record the code on another tape machine at the same time. To do so, connect the TIME CODE CH OUTPUT to the input jack of the appropriate channel of your second machine. The TIME CODE CH OUTPUT level is 2 V p-p (10.5 V).

2. Check to see the BR-20T's SPEED MODE is set to FIX.
3. Put the time code track into Record Ready by pressing its REC Enable switch. Its LED will start blinking.
4. Run the tape by pressing PLAY for about a minute of "leader".
5. Press the master REC key, and start the time code generator. The TIME CODE indicator will light up, indicating time code is being fed into the BR-20T.

The acceptable range of time code is 0.3 to 20 V peak-to-peak (2 V p-p nominal).

6. After striping the entire length of the tape, rewind the tape to the beginning.
7. Release the track's REC Enable switch by pressing it. Its LED will turn off.

For playback of the time code track :

8. Connect the TIME CODE CH "OUTPUT" of the BR-20T to the appropriate time code input (either Master or Slave) of the synchronizer.
9. To make sure that the time code was recorded, press PLAY. The TIME CODE LED will turn on solid. The time code display on the synchronizer or reader should increment. To verify that the machine is getting time code (and not counting tach pulses), temporarily unplug the ACCESSORY 1 connection from the BR-20T. If the reader still is running, and it stops and starts as you stop and play the BR-20T, you have successfully recorded the time code track.

NOTE : Once the time code track is complete, disconnect the TIME CODE CH INPUT connection or turn off the time code generator. This will make the output of the audio tracks cleaner.

■ An Introduction to SMPTE Time Code

SMPTE is an acronym for the Society of Motion Picture and Television Engineers. The SMPTE Time Code was defined in 1970 (C98.12: time and control code for video and audio tape for 525/30 television system). This specification has now become accepted as a universal standard, although additional practices have been informally added over the years (i.e., drop frame), as explained below.

The 1970 SMPTE code is an 80-bit digital code which designates the exact location in hours, minutes, seconds, and frames. There are 24 frames/second in film time code, and 30 frames/second on television time code. Some of the bits in the time code are undefined "user bits," and are often used to identify takes or production sequences, or for special functions (opening and closing automated theatre curtains, for example).

Drop Frame Time Code

It used to be true that U.S. television operated at 30 frames/second, but that was in a monochrome ("black and white") world, and current NTSC (National Television Standards Committee) standards utilize 29.97 frames/second for color TV broadcast. This means that an hour of 30 frame/second code is about 3.6 seconds too long when run at 29.97 frames/second. In order to remedy the problem, a slightly different time code format known as "DROP FRAME" was developed. In drop frame, one frame is dropped (skipped) every 108 frames, except that every tenth minute the frames are not dropped. In some cases, the differ-

ence between drop frame and standard TV time code is not significant. However, it is important to know what type of code is being utilized, and to set up the synchronization system accordingly.

EBU Time Code

The European TV time code equivalent of SMPTE code is known as EBU (European Broadcasting Union) code. It is very similar to SMPTE monochrome TV code, except that it runs at 25 frames per second, not 30. No drop frame format is required with EBU code.

VITC Time Code

A new format is the Vertical Interval Time Code (VITC). Basically, this is SMPTE TV time code, with a few extra bits for special control codes and error correction. The difference, however, is that instead of recording it in a continuous longitudinal track (recorded in a strip along the edge of the video tape by a fixed audio head), the VITC is recorded in vertical bursts, during the vertical retrace interval, by the rotating video head. This method enables time code to be read while the video image is in "still frame" mode.

Time Code Equipment and Interface to the BR-20

A tape synchronizer using SMPTE/EBU time code, reads the time code from a master machine (ATR or VTR) and from slave machines. It then compares the tape addresses in code of both the master and slave machines, making the slave machine "chase", adjust itself, using fast-forward or rewind mode to a point that corresponds to the tape address on the master. Upon completing the chase maneuver, the synchronizer will place the slave back into play mode. It will continue to monitor the master and slave in this way using the slave's capstan servo control to make any adjustments necessary.

An editing machine also uses time code addresses on tape as a means of monitoring any machines (ATR or VTR) that it is operating. It will use time code addresses to determine precise edit in and out points during the production of "rough cut" or master tapes, and also as cue points to perform any searches necessary.

Using this technology in the video environment improves the quality and quantity of available audio through the increased fidelity of audio dedicated machines and through the adaptability of multitrack audio machines. In audio only application, several multitrack recorders can be synchronized to achieve more available tracks, or multitrack and mixdown machines can be controlled automatically during remix or editing using time code.

SECTION 5 FEATURES AND CONTROLS

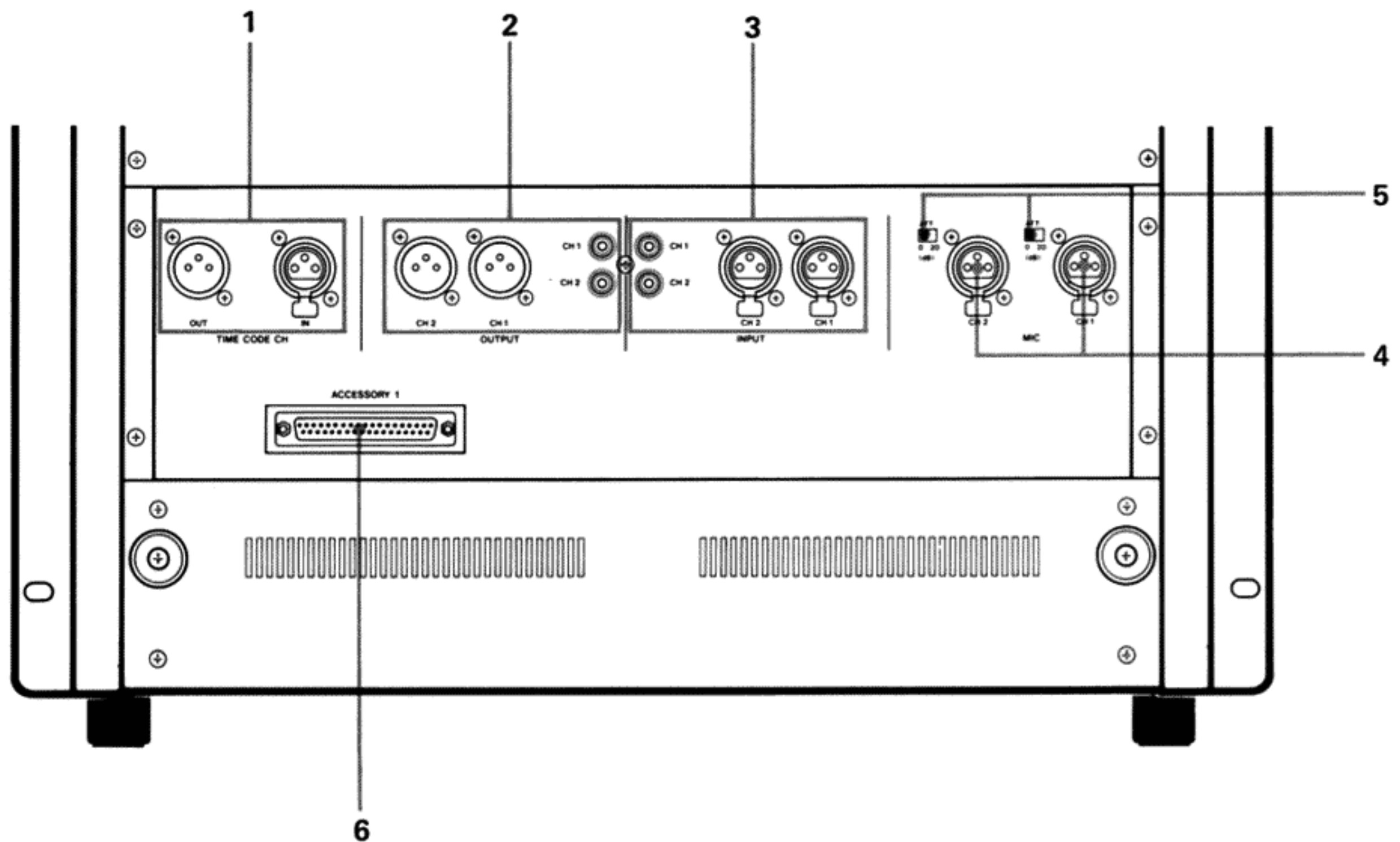

5-1. REAR PANEL

- 1 TIME CODE CH, IN and OUT (BR-20T only) :** The IN jack receives time code information from the ES-50 or other time code generators. The nominal input level is 2 Vp-p, balanced. The OUT jack carries the output of the time code channel and connects the synchronizer. The nominal output level is 2 Vp-p, balanced.
- 2 OUTPUT, CH1 and CH2 :** Typically, these are connected to the monitor section of a mixer, or directly to power amplifier inputs. The major difference between the two sets of jacks is their output level. The XLR type jacks have a nominal output level of +4 dBm, balanced. The RCA jacks have a nominal output level of -10 dBV, unbalanced. The pin assignment of the XLR type connector : Pin 1 shield (ground), pin 2 low (cold), and pin 3 high (hot).
- 3 INPUT, CH1 and CH2 :** They are for connection to mixer stereo outputs or other line level sources. The XLR type jacks have a nominal input level of +4 dBm, balanced. The RCA type jacks have a nominal input level of -10 dBV, unbalanced. The pin assignment : Pin 1 shield (ground), pin 2 low (cold), and pin 3 high (hot).

Both the XLR and RCA jacks are active at the same time ; disconnect whatever cable is connected to the jacks not being used.

- 4 MIC Input Jacks, CH1 and CH2 (optional) :** Connections for microphones. They accept a minimum input level of -72 dBm (0.195 mV). The maximum input level increases to -23 dBm (54.8 mV) when the ATT switch (item 5) is on. The input impedance is 1.2k ohms. The pin assignment : Pin 1 shield (ground), pin 2 low (cold), and pin 3 high (hot).
- 5 MIC ATT Switches (optional) :** These switches reduce the MIC input signal by 20 dB before it reaches the mic amplifiers.
- 6 ACCESSORY 1 Connector (37-pin, D-sub) :** It has the inputs/outputs necessary for the direct interface with the ES-50 Synchronizer or other SMPTE/EBU synchronizers/controllers.

Alternatively, this connector may be used for controlling the BR-20 transport from fader start/stop switches, or from the optional RC-402 remote control unit.

An internal DIP switch can be set for the BR-20 to respond only to the fader start command. (See page 12, switch S1-2, and also page 27, #43.)

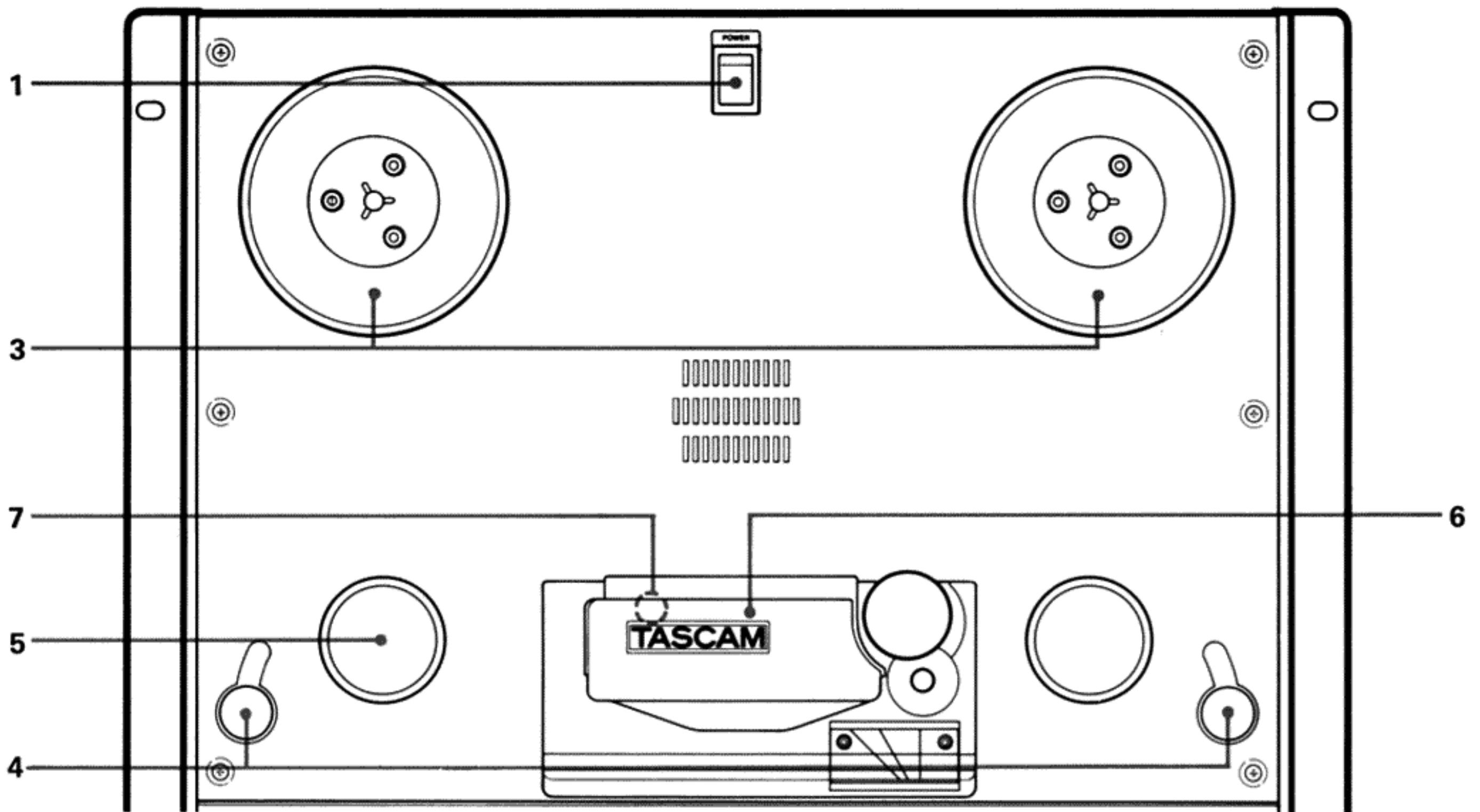

5-2. FRONT PANEL

1. **POWER Switch** : Controls AC power to the BR-20. As soon as power is turned on, the digital counter shows "8"s and some indicators light up. After about 3 seconds, the counter shows the tape run time you had before turning the power off and the indicators turn off, indicating the machine's logic circuitry has been initialized (i.e., all the control lines have achieved stand-by status).

CAUTION : The edge of a running tape could cut your fingers. Be sure to stop the tape before turning the POWER switch off.

2. **NAB Hub Adaptors (not shown in the illustration)** : These can be installed to allow use of large hub 10.5 inch (26 cm) reels.

3. **Reel Tables** : These support 10.5, 7 or 5 inch reels/quarter-inch tapes. The separate REEL SIZE selector switches should each be set to the appropriate positions for the size of reel in use.

4. **Tension Arms** : The capstan servo controls the tape tension and motor torque through the use of a position sensor attached to the right tension arm. The right tension arm is also associated with a shut-off mechanism that stops all tape motion if the tape slackens or spills off the reel. The left tension arm compensates for slight irregularities in the supply reel in addition to maintaining even tape tension.

5. **Guide Roller** : Correctly positions the tape along its path.

6. **Head Access Cover** : Pull off this cover to get access to the heads for cleaning and splice editing, or to a Monitor Source Selector switch (see the next item, # 7).

7. **Monitor Selector Switch (NAB standard U.S.A./Canada model only)** : This 3-position switch (located beneath the head access cover) controls what signal you hear through the internal local monitor speaker. This does not affect the PHONES output.

CH1 : for monitoring inputs fed into channel 1 or the output from track 1, depending on the transport modes and the position of the Output Source Selector switches.

CH2 : for monitoring the channel 2 input or track 2 output.

MIX : the channel (or track) 1 and 2 signals are combined together.

- The local monitor speaker can be ordered as an option if not premounted in your BR-20.

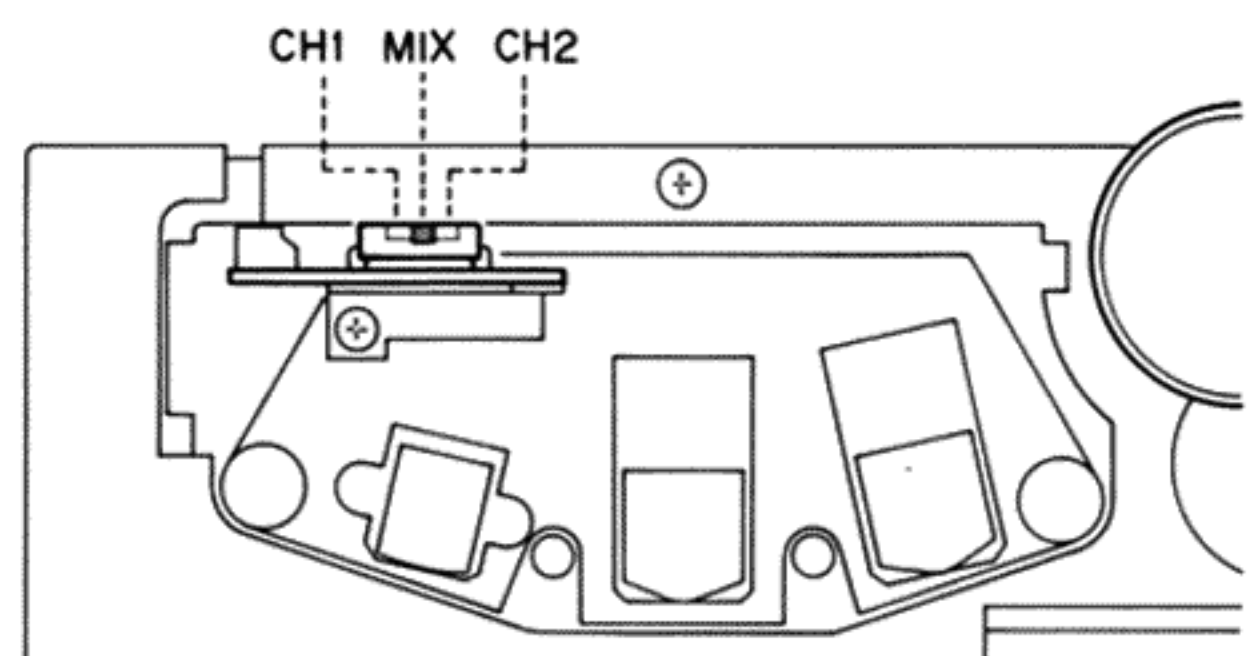

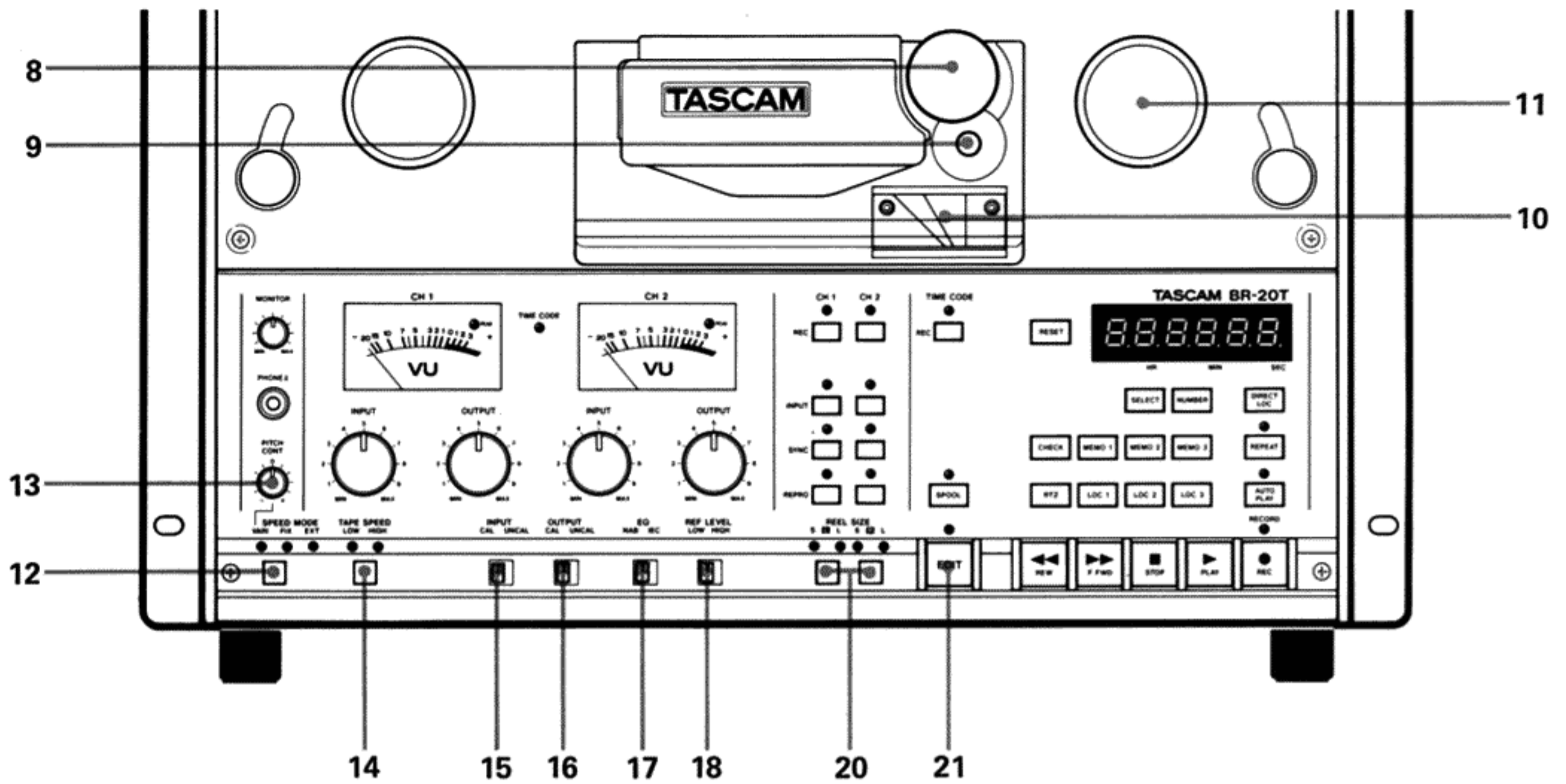

8. Pinch Roller : The BR-20's pinch roller is a "self-centering" type for maximum tape motion consistency. The rotating components are ball bearing supported for maximum resistance to wearing.

9. Capstan Shaft

10. Splicing Block : This precision aluminum splicing block has been provided to facilitate editing. Neat, uniform splices can be made by laying the magnetic tape in the slot, and using the block's pre-cut grooves to guide your razor blade.

11. Counter Roller : This measures linear tape footage, which is converted into elapsed time from whatever zero point is entered. The counter roller is associated with a tach generator to provide information about tape motion to external synchronizers during fast wind movements .

12. SPEED MODE Selector Switch : The switch determines the basic record/playback speed of the transport. One of the three LEDs is always on or flashing to show which speed has been selected.

FIX: Locks tape speed to 15 ips (38 cm/sec.) or 7.5 ips (19 cm/sec.) as selected by the TAPE SPEED HIGH/LOW switch. Setting to FIX is indicated by a green LED.

VARI : Switches tape speed control to the PITCH CONT knob. "Non standard" tape speeds can then be used. Setting to VARI is indicated by a red LED.

EXT : The yellow EXT LED lights solid when the BR-20 capstan motor is under external control of a synchronizer/controller connected to the ACCESSORY 1 connector on the BR-20's rear panel.

NOTE : Only when both the control and 9.6 kHz reference signals are coming into the BR-20, the EXT speed is active. When either signal is interrupt (due to poor or improper connection), the EXT LED will flash and the FIX LED will turn on solid, indicating the FIX speed is active.

FIX LED	EXT LED	Control Sig.	9.6 kHz Sig.	External Control
On Solid	Off	Both signals are not coming in.		NO
On Solid	Blinking	Only either the control or the 9.6 kHz signal is coming in.		NO
Off	On Solid	Both the control and the 9.6 kHz signal are coming in.		YES

13. PITCH CONT(rol) Knob : When and only when SPEED MODE selector switch is in its VARI position and its red LED is on, the PITCH CONT is active and provides a stepless plus or minus 12% variation to the capstan motor speed both in record and play modes. Turn the knob to the left to lower the motor speed, or to the right to increase the speed.

You can use this speed control to accommodate minor changes necessary in the length or relative pitch of your program material. If you're making a 30 second radio

commercial and it runs a little long, you can speed it up enough to drop out the extra seconds, although the material on it will raise in pitch. This can sometimes be used in a creative way to save parts that are a little out-of-tune, or to create sound effects such as flanging. If you record with the PITCH CONTROL at its maximum or minimum settings, you will NOT have the ability to make further adjustment in that direction upon playback.

Also, it is recommended that you run the BR-20 for several seconds in the play mode for the speed to stabilize, especially when the change in speed is large. Before beginning to record again, check the pitch carefully with a short playback, and you will have less troubles with drift.

CAUTION : The PITCH CONTROL affects the record speed also. Check to make sure that the SPEED MODE selector switch is set to FIX unless you are using the PITCH CONTROL intentionally.

14. TAPE SPEED Selector Switch : allows selection of two tape speeds during recording and playback modes. HIGH (green LED) for 15 in/s (38 cm/s) and LOW (orange LED) for 7.5 in/s (19 cm/s).

15. INPUT CAL/UNCAL Switch : When this switch is placed in the left/CAL position, the CH 1 and CH 2 INPUT level controls are bypassed and the input level is passed to the outputs without receiving any level alteration. This CAL position is generally used for system calibration (level alignment).
When the switch is set to its right/UNCAL position, the INPUT level controls are active, affecting the input signals.

16. OUTPUT CAL/UNCAL Switch : Similar to the INPUT CAL/UNCAL switch (item 15) ; when placed in the right/UNCAL position, this switch activates the CH1 and CH 2 OUTPUT level controls.

17. EQ Selector Switch, NAB/IEC: Different brands of tape require different equalization curve. Set this switch to match the type of tape in use for best frequency response and signal-to-noise ratio.

- When the optional MIC inputs are mounted, the EQ switch on the standard models gives place to CH 1 MIC/LINE switch and the EQ selection is made by a DIP switch on the MIC AMP PC Board.

18. REF LEVEL Selector Switch : Set this switch to match the type of tape being used. The HIGH position provides a 0-vu reference reading for standard 320 nWb/m level (or 514 nWb/m on "European" models), and the LOW position provides a 0-vu reading for 250 nWb/m (or 320 nWb/m on "European" models).

- When the optional MIC inputs are mounted, the REF LEVEL switch on the standard models gives place to CH2 MIC/LINE switch and the REF LEVEL selection is made by a DIP switch on the MIC AMP PC Board.

19. CH1 and CH2 MIC/LINE Input Selector Switches (optional): Used to determine which input, mic or line, is fed into the separate channels.

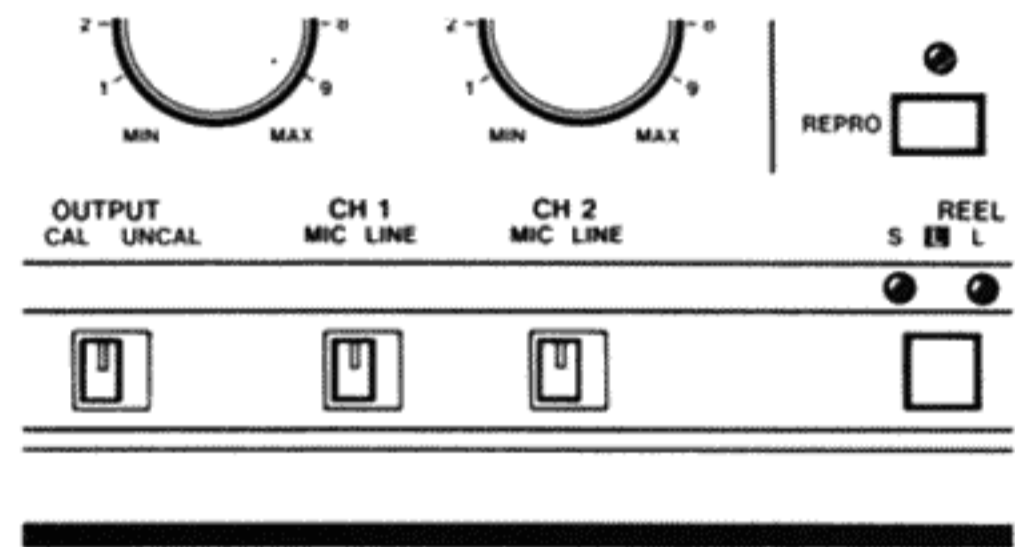

20. REEL SIZE Selector Switches : These should be set to match the size of reel in use for optimum tape tension and smooth tape behavior. L(arge) for 10.5 inch reels, and S(mall) for 7 or 5 inch reels, separately for the supply and the takeup side.

21. EDIT Key : This key provides the following 7 functions.

- 1) Manual Edit :** When the transport is in STOP and the right (takeup) tension arm is in its up/"on" position, pressing EDIT will turn on its LED and disengage the reel motor brakes, and the same amount of torque will be exerted on both reels. The reels may be "hand rocked" to locate the exact edit points while you hear the tape.

Move by hand backwards and forwards

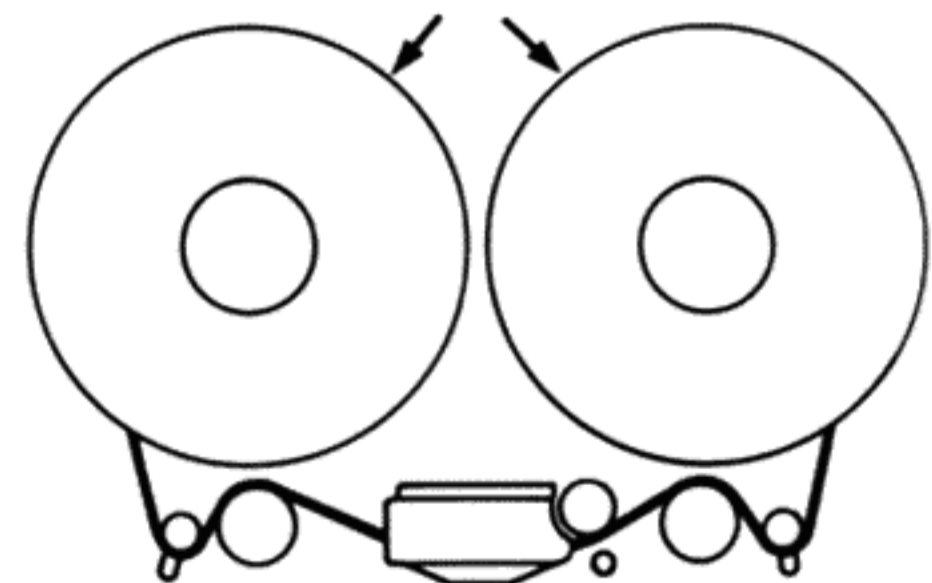

Cueing out the edit points

2) **"Quick Cueing"** : While in Manual Edit mode (above), if you hold REW or F.FWD, the tape lifters will retract so the tape contacts the heads, allowing you to hear tape as it runs at REW or F.FWD speed.

A high-cut filter is automatically inserted to prevent the meter circuits and speaker components from being damaged by high-energy audio signals.

3) **Intermediate Speed Cueing** : Holding EDIT together with REW or F.FWD in Manual Edit mode, you will hear tape as it runs at about half times the normal fast wind speed.

4) **Stop Edit** : When the transport is in STOP and the right tension arm is dropped to its "off" position, pressing EDIT will turn on its LED and disable the output mute. The tape may then be pulled forward off the supply reel as you listen to it play.

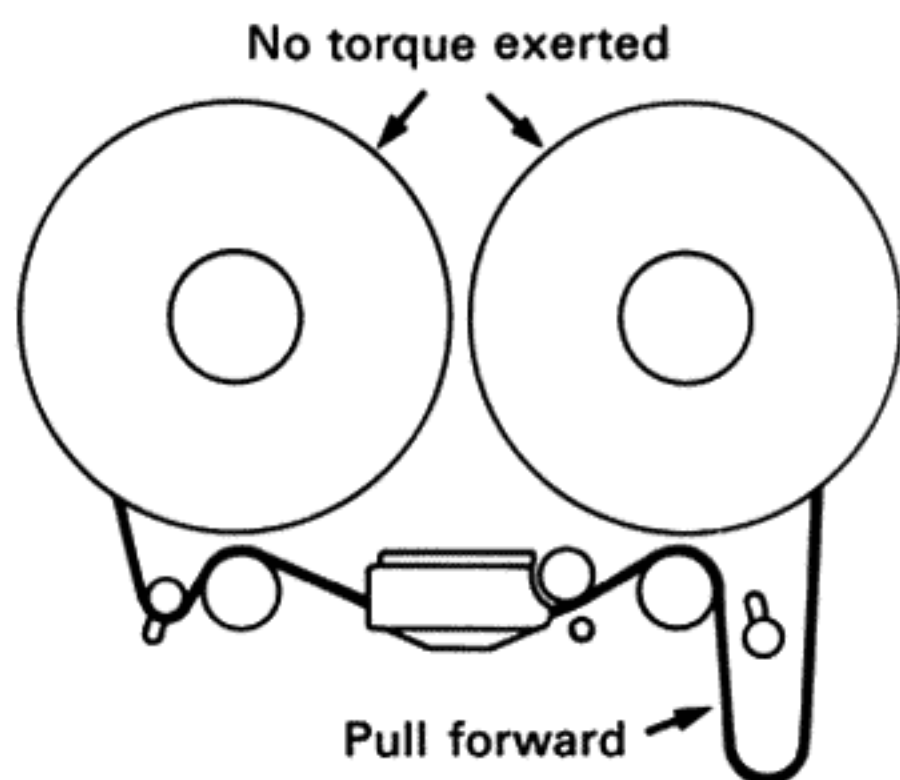

5) **Dump Edit** : If EDIT and PLAY are simultaneously pressed when the transport is in STOP, the EDIT LED will turn on and the tape will begin unthreading itself from the supply reel as you listen to it play. The right tension arm position is disregarded by the shut-off sensing logic.

To stop the tape motion and quit the mode, press STOP.

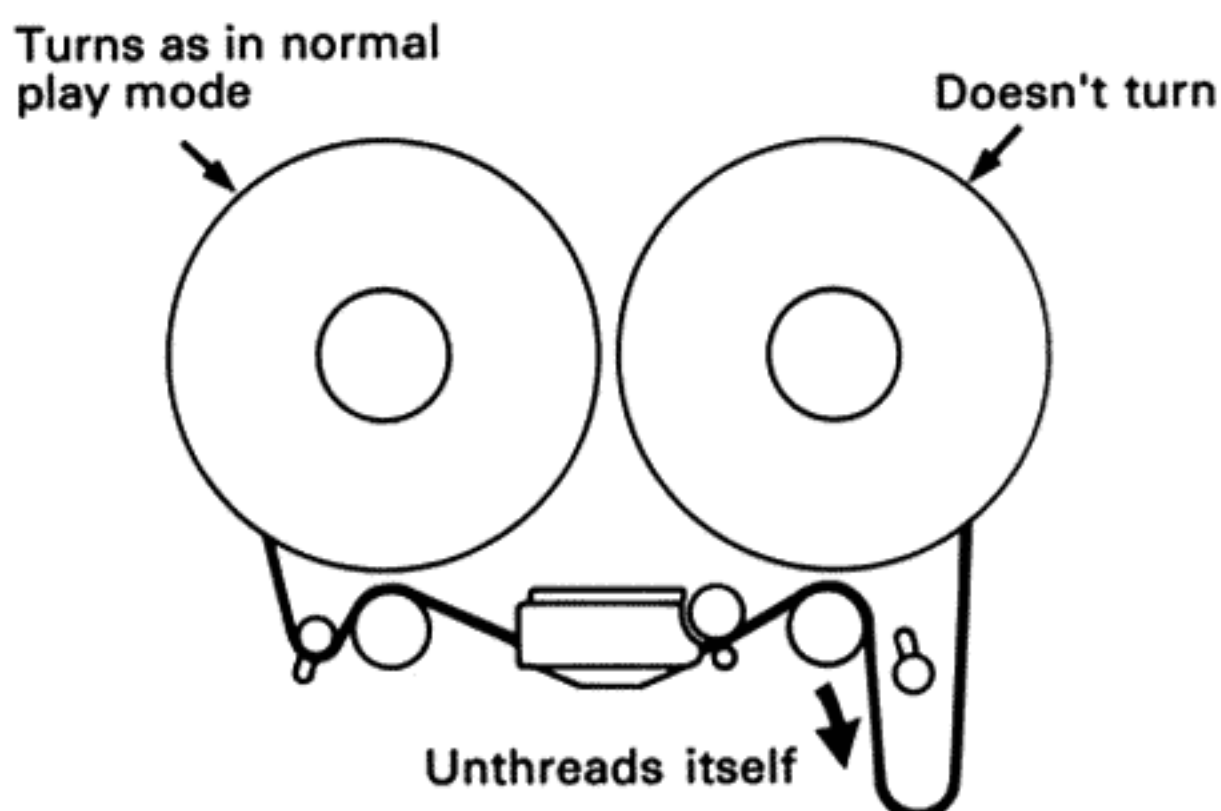

6) **Spot Erase** (not available on the NAB standard U.S.A./Canada model) : This function makes it easy to erase specific portions on a given track. First, designate the track to be erased by pressing its REC Enable switch. In Manual Edit mode, hold the master REC key while slowly moving tape by hand. Erase continues for as long as you advance the tape with REC held down.

CAUTION : The key to a clean Spot Erase is keeping constant tape speed before, during, and after the pressing and releasing of the record key. If the record function is activated before tape movement or deactivated after the tape has stopped, an audible click will be left on the tape. If you are not already familiar with using spot erase, we advise you to practice before attempting the spot erase function on master recordings.

7) **High-speed Cueing** : This is similar to the "Quick Cueing". Hold EDIT during the fast winding modes (including SPOOL and LOCATE). For as long as you hold EDIT, you can hear tape.

As in "Quick Cueing" mode, a high-cut filter is automatically inserted.

NOTE : Pressing PLAY after EDIT only causes the tape to play normally. To activate Dump edit mode, hold EDIT and press PLAY, or press both simultaneously.

22. **SPOOL Switch** : When this switch is pressed after (or before) REW or F.FWD, the tape will begin rolling at a constant speed of about 100 ips (2.5 cm/s), which is 1/3 times the normal fast wind speed, to obtain a tight, uniform tape pack. Generally, spooling will be done onto the takeup reel at the end of a recording or editing session so the tape can be stored "tails out", which reduces audible print-through effects (pre-echoes).

23. **REW Key** : a) Winds the tape at high speed in reverse if pressed in STOP. b) Holding the key while in EDIT (or, inversely, holding EDIT while in REW) offers reverse tape cueing.

24. **F.FWD Key** : Similar to REW. a) If pressed in STOP the key winds the tape at high speed in the forward direction. b) Holding the key while in EDIT (or, inversely, holding EDIT while in F.FWD) offers forward tape cueing.

25. **STOP Key** : Stops any tape motion, and disables all transport modes.

26. **PLAY Key** : a) Pressing this key alone starts playback. b) Pressing the key during recording stops the recording ("punch out") without stopping the tape motion.

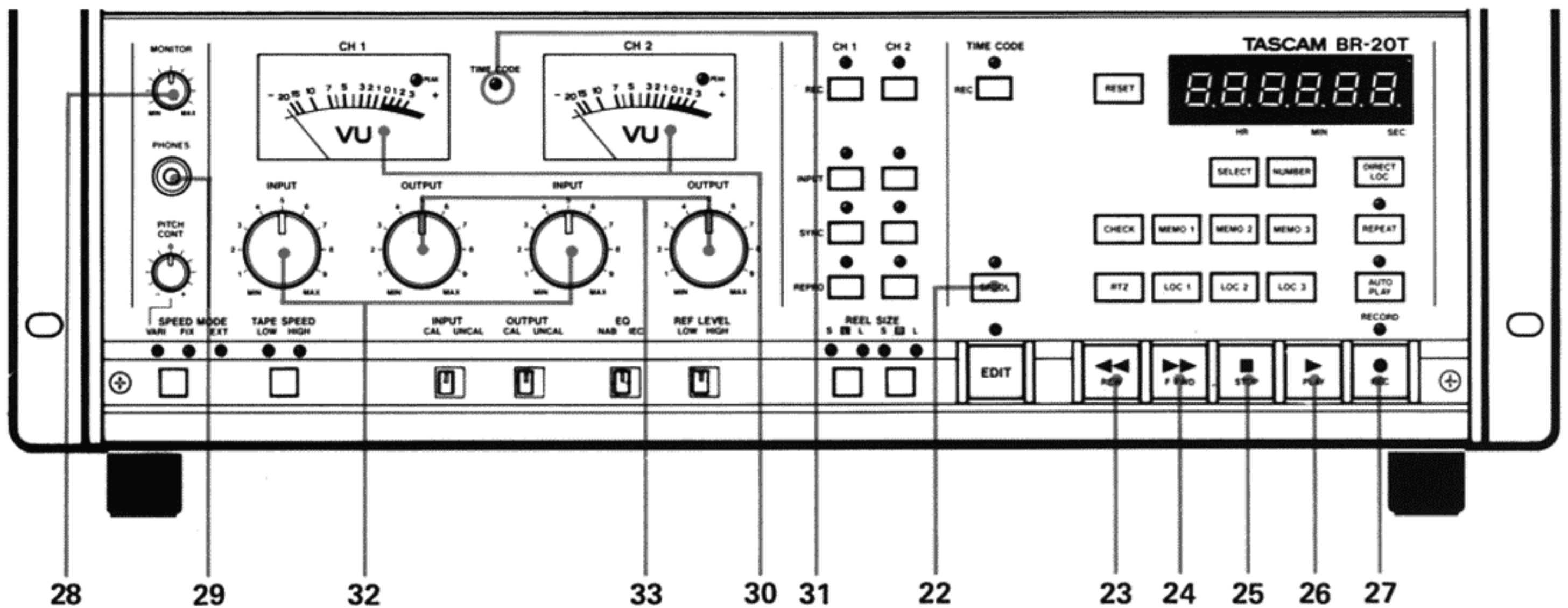

27. REC Key : Pressing REC together with PLAY will cause either of the following events :

- 1) If either or both tracks' REC Enable switches are on, the track LED(s) turn on solid, and recording will begin.
 - Recording can also be initiated by pressing REC during PLAY.
- 2) If both tracks' REC Enable switches are off, the master REC LED will blink to indicate a record ready.

The above 5 keys (REW, F.FWD, STOP, PLAY, and REC) can optionally be laid out to match your preference. Consult TASCAM or your nearest TASCAM dealer.

28. MONITOR Level Control : Adjusts the listening level of the headphones plugged into the PHONES jack.

NAB standard U.S.A./Canada model — Plugging headphones into the PHONES jack electronically disconnects the internal local monitor speaker. Disconnect the headphones for the internal speaker to be active. For as long as the PHONES jack is empty, the MONITOR level control affects the level fed to the internal monitor speaker.

29. PHONES Jack : For connection to stereo headphones only. Don't use 2 conductor mono headphones with this jack. The built-in headphone amplifier is rated at 150 mW into 8 ohm load.

30. VU-meters with PEAK Indicator : The meters register Input and Tape signals. Whether measured signals is Input or Tape depends on both the transport modes and the setting of the Output Source Selector switches (item 35).

The meters will read 0 VU when a signal of +4 dBm is fed into the XLR type input jacks or a signal of -10 dBV into the RCA input jacks. The PEAK indicator is designed to light at 12 dB (if REF LEVEL is at LOW) or 10 dB (with REF LEVEL at HIGH) above nominal input level. If the PEAK indicator constantly lights, turn down the INPUT level control until the indicator flashes only occasionally.

31. TIME CODE Indicator (BR-20T only) : Lights to indicate time code is being fed into the time code channel of the BR-20T. Also lights up in playback of the time code track.

32. INPUT Level Controls : These controls set the level of their respective channel's inputs (both XLR and RCA jacks).

They are used for recording level/balance adjustments.

- Active only when their respective INPUT CAL/UNCAL switches are in UNCAL position.

33. OUTPUT Level Controls : These controls set the level of their respective channel's outputs (both XLR and RCA jacks), and are used for playback level adjustment.

- Active only when their respective OUTPUT CAL/UNCAL switches are in UNCAL position.

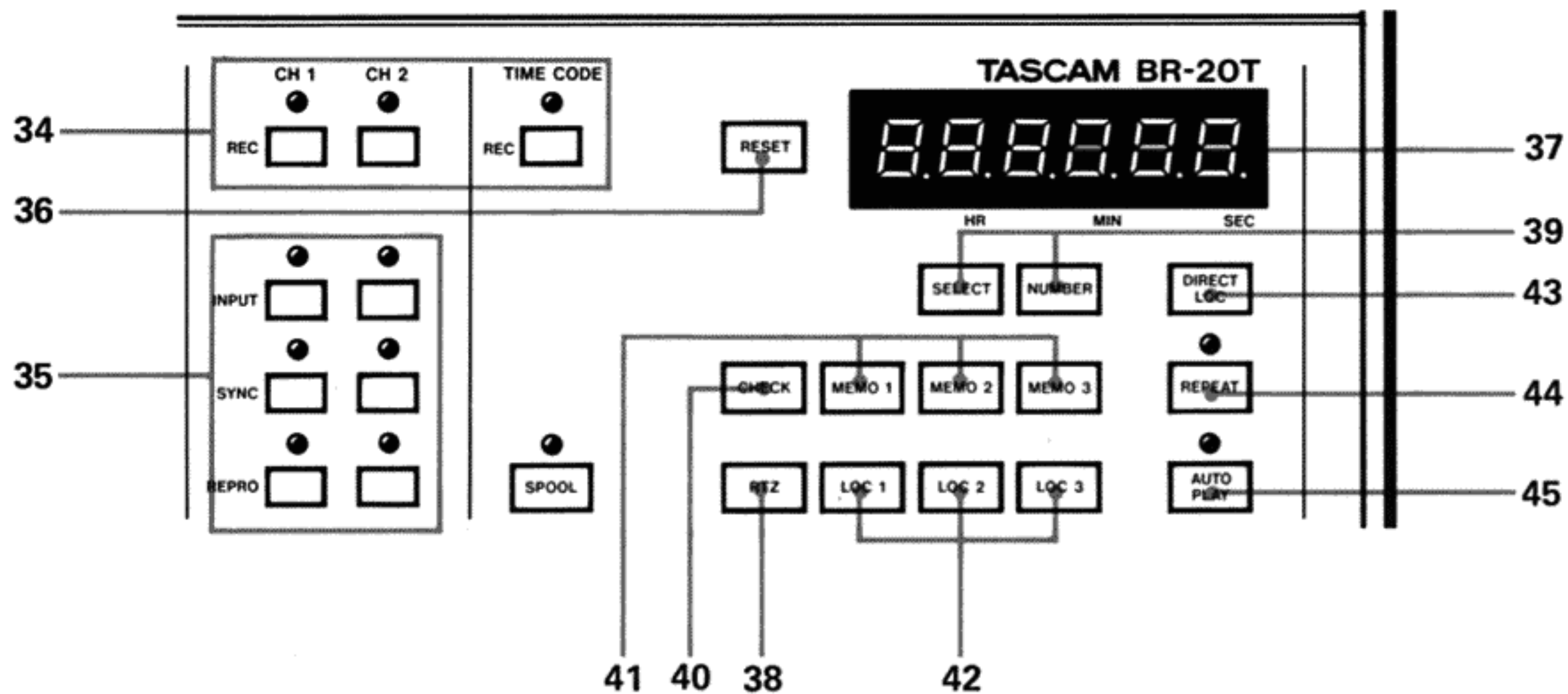

34. REC Enable Switches : These switches put the respective tracks into Record Ready, or directly into Record mode if the master REC and the PLAY key have already been pressed.

Functions of the track REC LEDs

- a) LED off : safe — no recording cannot occur on that track.
- b) LED blinking : record ready — recording on that track will occur when the master REC and the PLAY key are pressed.
- c) LED on solid : record mode — recording is taking place on that track.

35. Output Source Selector Switches : These switches determine the source of the signal which is fed to the output connectors, the VU meters, and the PHONES jack, as follows :

INPUT (red LED) : Selects the input to the track (primarily for alignment). This is the same as the E-to-E function on a video tape machine.

SYNC (orange LED) : Selects the rec/sync head signal for synchronous playback, or the input signal, as follows :

When the transport is in Play mode, the output of the channel whose REC enable switch is on (its LED blinking) is fed with the respective track signal; and when the transport switches to Record mode, that output is fed with the input signal.

REPRO (green LED) : Select signal from the repro head. This is used primarily for alignment or evaluation of the quality of the recorded signal, although it can be used during mixdown. Actually, the SYNC and REPRO head performance is equivalent, so there is no need to use REPRO for mixdown.

NOTE : During recording you can toggle INPUT and REPRO, but can't toggle from these to SYNC. If you press SYNC after recording has started, the monitor will switch to SYNC only at the punch-out moment. Similarly, if you press INPUT after recording has started in SYNC, the monitor will switch to INPUT at the punch-out moment, allowing you to continue to monitor the input signal.

Output Source Selector Sw.	Track REC Enable Sw.	Transport Mode	Monitor Source
INPUT	N/A	Stop	Input
REPRO	N/A	Play	Tape
SYNC	On	Play	Tape
		Record	Input
	Off	Play	Tape
		Record	

N/A = not applicable ; the REC switch on/off has no effect on the output source.

- **On the BR-20T only :** the green REPRO LED will flash at slow rate to indicate the time code track is not read off in sync with the audio tracks. Prevent or defeat this problem by setting the Output Source Selector switch to SYNC.

36. RESET Switch : When pressed, this switch resets the digital display to 00000. Used to mark the record start point or any other points on the tape. The tape will be located to that point by pressing the RTZ (Return-To-Zero) key.

Pressing RESET has no effect when the counter is in SELECT/NUMBER and CHECK modes (see below).

37. Digital Tape Time Counter : This 5-digit display shows elapsed time in hours, minutes and seconds.

The maximum readout time is 9 hours, 59 minutes, 59 seconds, and the minimum readout time is -9 hours, -59 minutes, -59 seconds.

The elapsed time is calculated from the speed setting. When SPEED is set to LOW, the information from the capstan motor is automatically multiplied by two for you.

38. RTZ (Return-To-Zero) Key : When this key is pressed in whatever the current transport mode is, "00000" will flash in the counter for a fraction of a second then the tape will fast wind to the counter 00000 point. If AUTO PLAY is active, the tape will automatically start playing back after reaching the counter zero point.

39. SELECT Key : When this is pressed for the first time, the digital display switches to MEMO point setting mode.

Each time SELECT is pressed, a blinking "0" will move left.

Each time NUMBER is pressed, blinking numbers scroll up.

When the desired location time is entered, press one of the three MEMO keys. That point is loaded into the corresponding MEMO register and the counter switches back to the normal tape time display mode.

For more details on SELECT, see the "Operation" section of this manual (pp. 16-17).

40. CHECK Key : When this key is pressed, the counter will switch to show a broken line. Holding then any MEMO key causes the counter to show the content of the corresponding register.

When REPEAT play is in progress, or in Ready with its LED blinking, if CHECK is pressed then REPEAT is held, the counter will show which of the three MEMO is assigned to the start point of the loop and which MEMO is assigned to its end point.

NOTE : Pressing CHECK during SELECT/NUMBER operation clears the numbers you entered and the display switches back to tape run time mode.

41. MEMO Keys 1-3 : These three keys are used to load tape locations defined by SELECT/NUMBER into the respective registers, or to capture the current tape location.

"On-the-fly" MEMO entry :

When any of the MEMO is pressed while tape is playing, the counter shows a broken line for 3 seconds, then the readout you had the moment

MEMO was pressed is loaded into that memory register. The BR-20 can optionally be modified so the tape point captured by hitting MEMO is stored into memory only when NUMBER is additionally pressed. (See page 12, "S2-1".)

42. LOC Keys 1-3 : Pressing any of these three keys causes the tape to roll (in either REW or F.FWD) to the corresponding MEMO point. The instant LOC is pressed, the counter display will show the location point for a fraction of a second.

If AUTO PLAY is active, the tape will automatically start playing back as soon as a MEMO point is reached.

43. DIRECT LOC Key : If this key is pressed instead of MEMO at the end of SELECT/NUMBER operation, the tape will be located to the point you've entered via SELECT and NUMBER.

If DIRECT LOC is pressed during any other operations than SELECT/NUMBER, the counter will show for a fraction of a second the beginning point of the last record or play (whichever you performed after the other) and the tape will be located to that point. If AUTO PLAY is active, the tape will start playing from that point.

Fader Start Function On/Off Switching

Holding STOP and pressing DIRECT LOC will switch the fader start (not stop) function on and off. Each time DIRECT LOC is pressed, the leftmost dot in the counter display will turn on and off, showing that the BR-20's transport can (dot off) or cannot (dot lit) be started from external fader switches.

The fader stop function on/off switching is a task of a DIP switch (see page 12).

44. REPEAT Switch : The REPEAT function provides a "playback loop" or "block repeat" between the desired two of the three MEMO points. The machine understands the lower memory point as the start point of loop, and the higher point, as the end.

For more details see the Operation section of this manual, p. 17.

45. AUTO PLAY Switch : This switch programs the BR-20 to start playback after any of these search operations : DIRECT LOC, LOC 1-3, and RTZ.

The AUTO PLAY switch can be pressed before or after starting the search operation.

SECTION 6 OPTIONAL ACCESSORIES

Remote Transport Control Unit



This comes equipped with a 15-foot (5-meter) cable that plugs into the ACCESSORY 1 connector of the BR-20, and controls the basic tape motions (REW, F.FWD, STOP, PLAY, and REC). This can also be used to control the TASCAM MSR-24/16 and TSR-8 tape transports.

RE-1004 10-1/2" Metal Reel (for 1/4 inch wide tapes)



CS-608/607B Console Rack



SMPTE/EBU Synchronizer/Controller



Mic Amplifier Kit

Lets the BR-20 accept two microphone signals. The kit includes a two-channel input amplifier assembly with two input jacks and attenuator switches.

Monitor Speaker Kit

This is a local monitor speaker assembly to be mounted in the BR-20. The monitor source can be channel 1, channel 2, or both channels mixed together, as required. (Premounted in the NAB standard USA/CANADA model.)

TZ-261 Cleaning Kit (Except U.S.)

HC Head Cleaner & RC Rubber Cleaner (U.S. only)

CS-608 DIMENSIONS

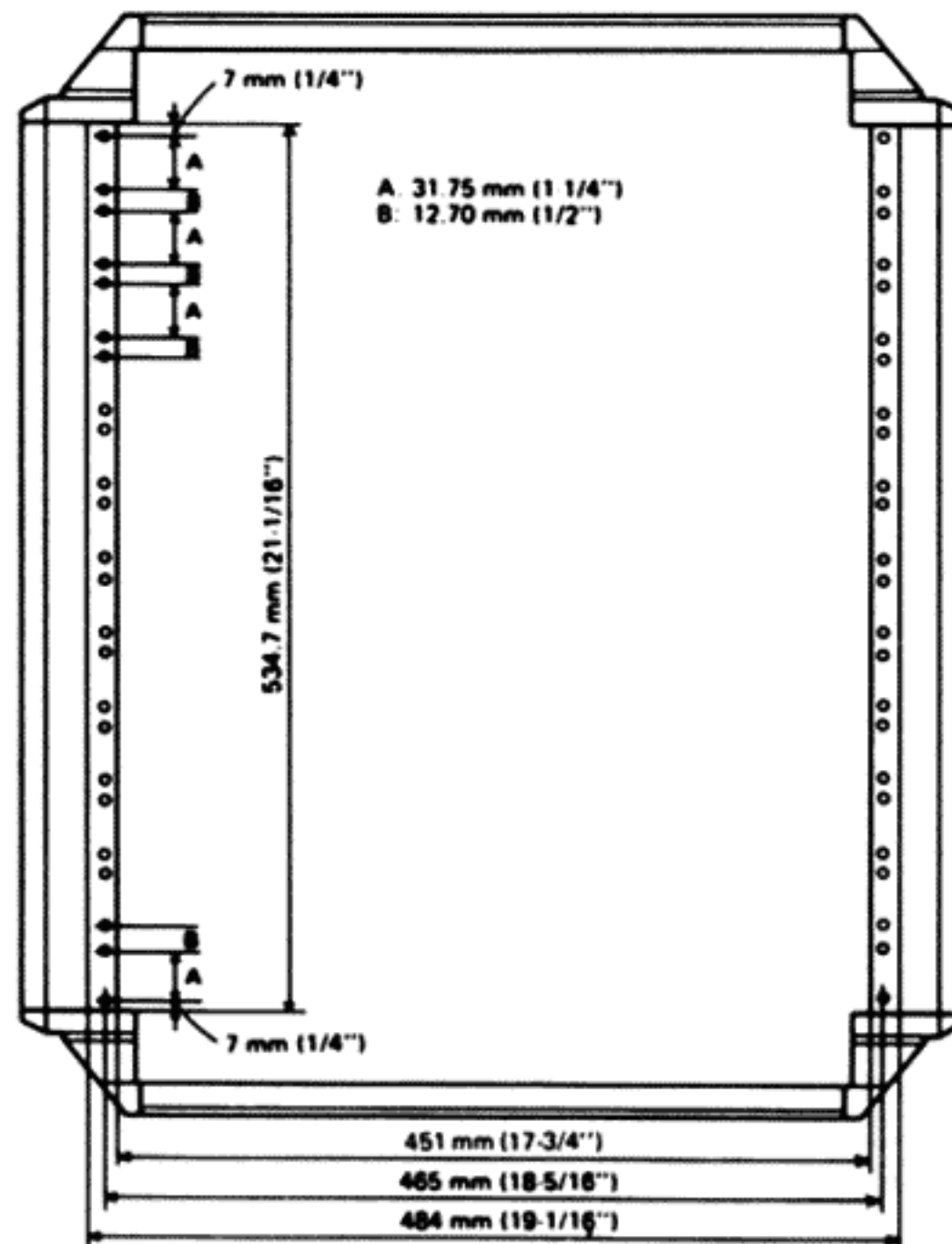
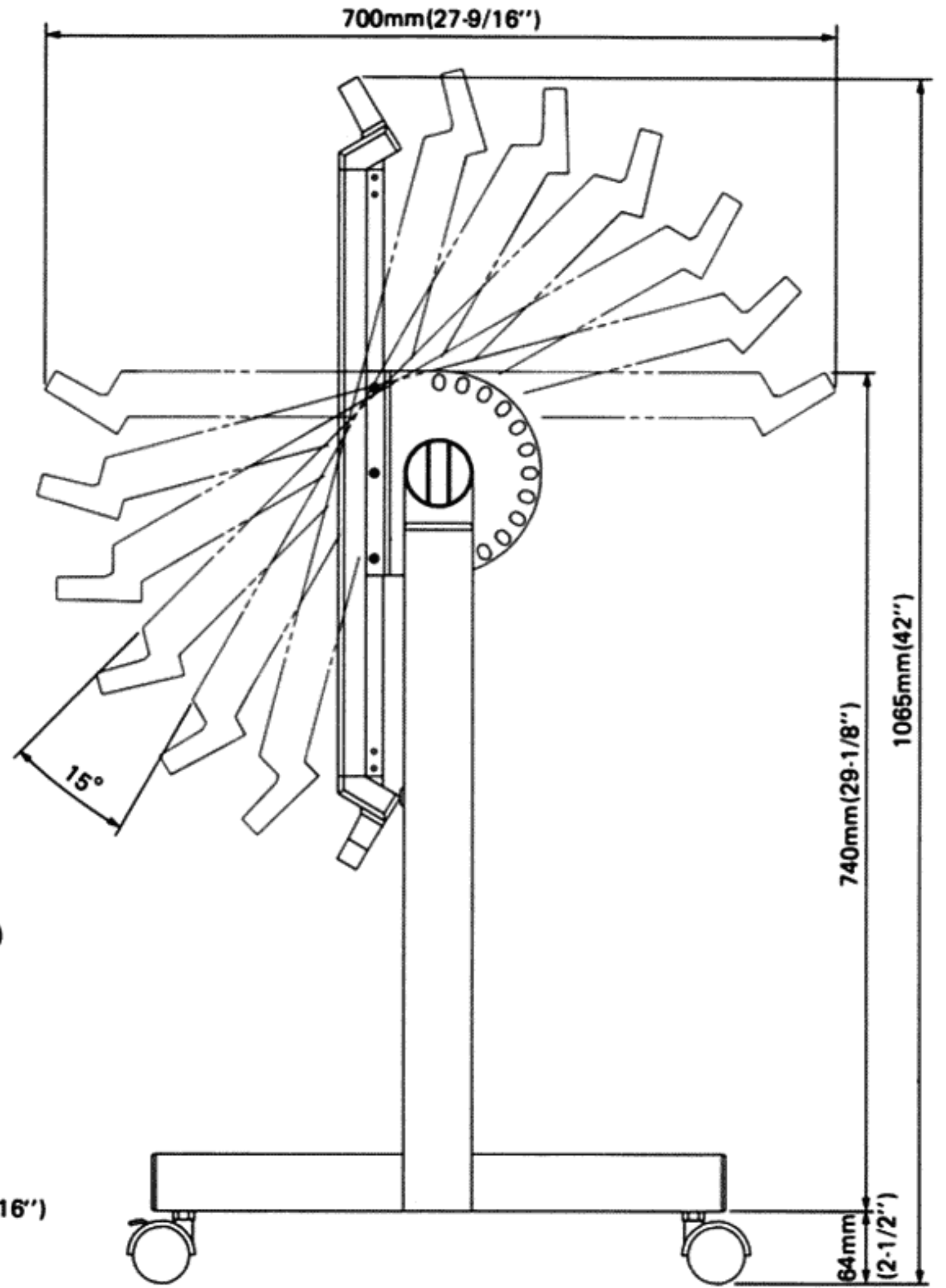
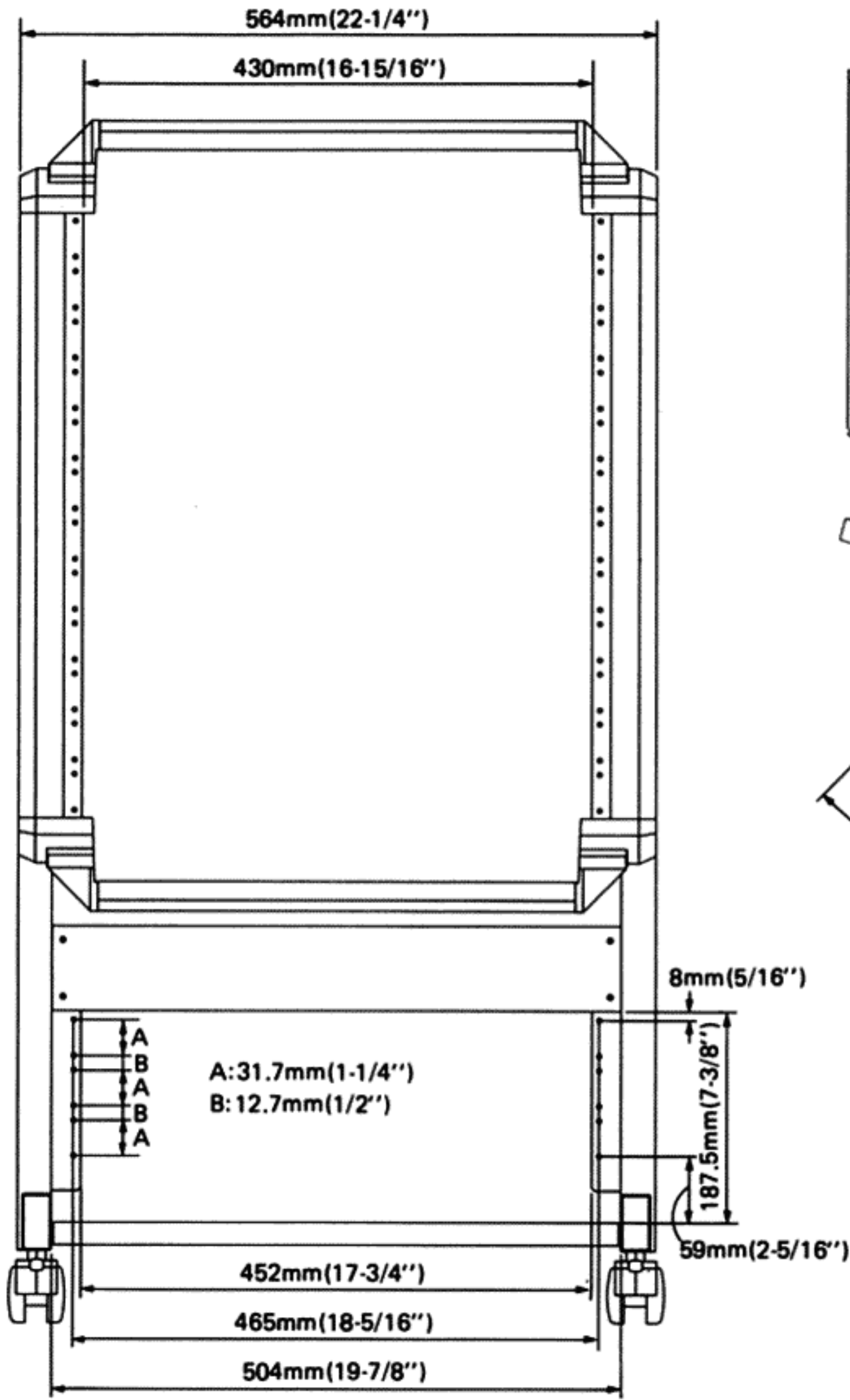

SECTION 7 CARE AND MAINTENANCE

We can't stress the importance of cleaning and demagnetizing too much. Oxide shed from the tape and accumulated on the heads and other components in the tape path and dust or debris picked up from the air can result in poor high frequency response. Also, the heads may become magnetized. This residual magnetism can increase noise and distortion, significantly degrading record/reproduce performance. Clean up and demagnetize at least every day before you start to work with the BR-20.

CLEANING

1. Remove the head cover to get full access to the heads. See "How to Remove ...", page 11.
2. Apply cleaner to a cotton swab or lint-free gauze and wipe the entire surface of the tape path. Wipe off any excess cleaning fluid with a dry swab.

CAUTION : Be sure to use a good cleaner. We recommend the following:

TEAC CH-1 (U.S. only) or TZ-261A (for heads, tape guides, guide roller, counter roller, and capstan shaft); and

TEAC RC-1 (U.S. only) or TZ-261B (for pinch roller).

DEGAUSSING (DEMAGNETIZING)

A little stray magnetism can become quite a big nuisance in tape recording. It only takes a small amount (.2 Gauss) to cause trouble on the record head. (Gauss is the unit used to measure magnetism.) A little more than that (.7 Gauss) will start to erase high frequency signals on previously recorded tapes. You can see that it's worth taking the trouble to degauss regularly.

DEGAUSSING IS ALWAYS DONE WITH THE RECORDER TURNED OFF. If you try it with the electronics on, the current pulses produced by the degausser will look just like audio signals to the heads. These pulses are around 10,000 Gauss, and will seriously damage the electronics and/or meters. Turn off your BR-20, then turn on the degausser at least 1 m (3 feet) away from the recorder.

Be certain that your degausser has either a plastic cover or plastic tape covering the tip. Make sure that no metal ever touches the tape heads as it will scar them and ruin them.

Slowly move in to the tape path. Move the degausser slowly back and forth, touching lightly all metal parts in the tape patch. Slowly move it away again to at least 1 m (3 feet) from the recorder before turning it off.

Be sure to concentrate while you are degaussing. Don't try to hold a conversation or think of anything else but the job you are doing. If the degausser is turned on or off by accident while it is near the heads, you may put a permanent magnetic charge on them that no amount of careful degaussing will remove. You will have to get the heads replaced. Make sure you are wide awake for this job.

A clean and properly demagnetized tape recorder will maintain its performance without any other attention for quite a while. It won't ruin previously recorded material, nor will getting it back to original specifications be difficult.